

FLEXON

High Quality Chains

FÖRDERKETTEN
CONVEYOR CHAINS
2006/2007

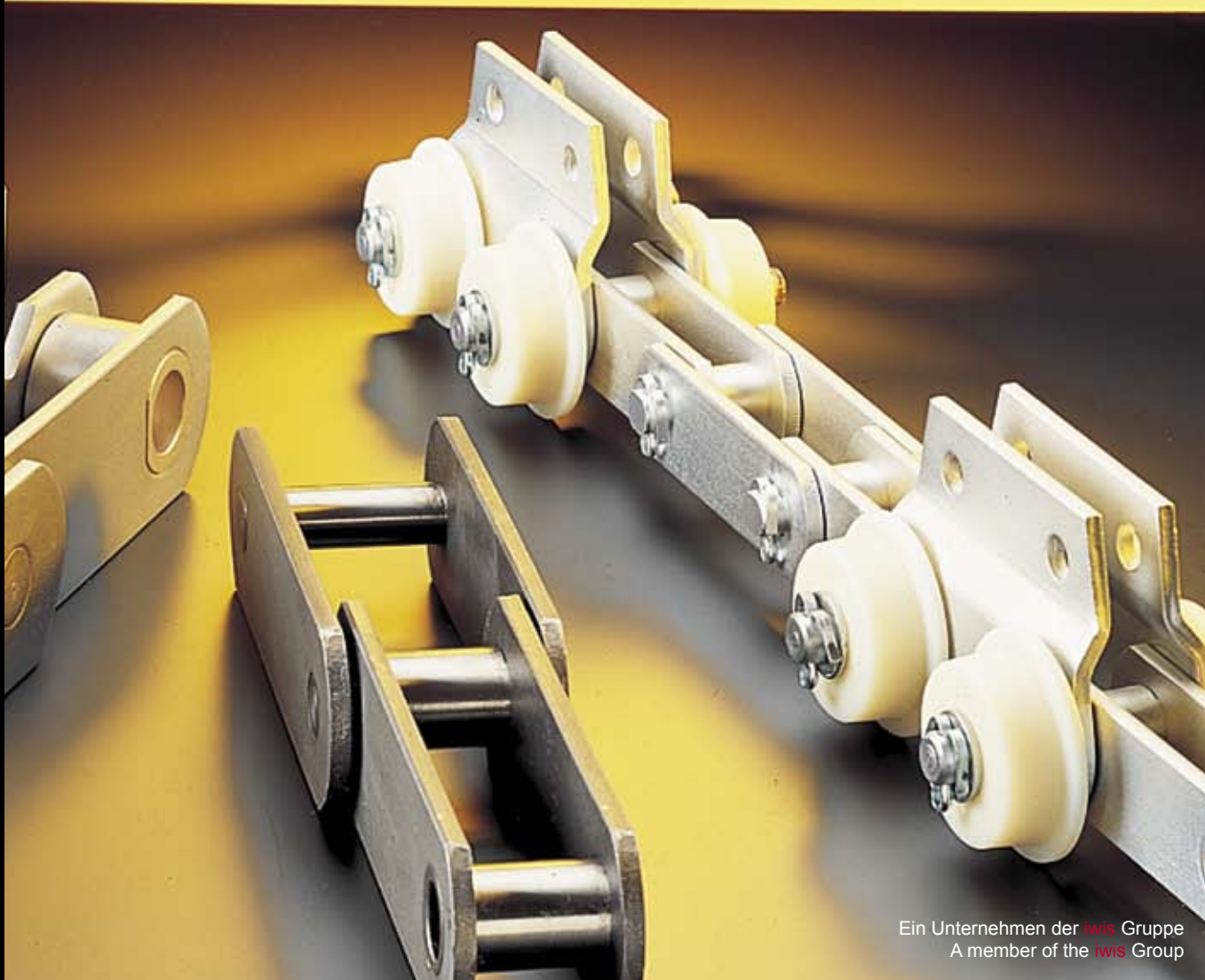

Ein Unternehmen der **Iwis** Gruppe
A member of the **Iwis** Group

IMPRESSUM IMPRINT

© Copyright Flexon GmbH, Wilnsdorf, Germany 2006

Der Inhalt dieses Katalogs ist urheberrechtlich durch den Herausgeber geschützt. Jede gesamtheitliche oder auszugsweise Verwertung des Inhalts ist ohne Zustimmung des Herausgebers unzulässig und strafbar. Bei der Erstellung des Katalogs wurde äußerste Sorgfalt angewandt, nichtsdestotrotz übernimmt der Herausgeber keine Haftung für eventuell auftretende Fehler und Auslassungen insbesondere im technischen Bereich.

The contents of this catalogue are the copyright of the publisher and may not be reproduced (even extracts) unless permission is granted. Every care has been taken to ensure the accuracy of the information contained in this catalogue but no liability can be accepted for any errors or omissions.

D/E, 11/2006

FLEXON – Eine Kette von Spezialisten

FLEXON – A chain of specialists

Flexon ist seit dem Jahr 1980 auf dem Markt der Antriebs- und Fördertechnik aktiv und hat dabei sein Angebot stets konsequent auf Kundenbedürfnisse ausgerichtet.

Heute ist Flexon mit seinen Marken **eire** und **ecoplus**® ein international tätiges, hochspezialisiertes Dienstleistungsunternehmen der Antriebstechnik. Die Flexon Produktpalette umfasst Rollenketten, Landmaschinenketten, Spezialketten, Flyerketten, Kettenräder und Zubehör für alle Anwendungsgebiete. Industrie, Landwirtschaft und viele andere Bereiche profitieren neben der hohen Qualität und Zuverlässigkeit der Flexon Produkte vor allem von der Flexibilität der Serviceleistungen.

Das über einen Zeitraum von 25 Jahren entwickelte Know-how der Unternehmensbereiche Forschung und Entwicklung, Logistik und Qualitätsüberwachung und Services bildet die Grundlage des heutigen Unternehmens mit seinen 100 Mitarbeitern.

Im Marktsegment „Erntemaschinen“ hat Flexon in Europa Marktführerschaft erreicht. Flexon bietet die breiteste Produktpalette von hochqualitativen Rollen- und Landmaschinenketten und Kettenrädern zusammen mit einem umfassenden Serviceprogramm an nahezu sämtlicher Erstausrüster in Europa an.

Mit den Standorten Wilnsdorf (Nordrhein-Westfalen), verantwortlich für die Produktbereiche Rollenketten, Spezialketten und Kettenräder und Sontra (Hessen), verantwortlich für den Produktbereich Landmaschinenketten sowie Verkaufsbüros und Auslieferungsläger in Europa und den USA, bietet Flexon eine optimale Logistikkette für die Betreuung unserer internationalen Kunden an.

Wir garantieren unseren Kunden bestmögliche Lösungen auch bei anspruchsvollen und schwierigen Aufgabenstellungen. Wir wachsen in einem umkämpften Markt, weil unsere konsequente Orientierung auf Service- und Dienstleistungen unsere Kunden zu Partnern macht. Dahinter steht das Know-how unserer zahlreichen Spezialisten in Entwicklung, Produktion, Qualitätskontrolle, Vertrieb und Service. Branchenweit vorbildlich und ausschlaggebend für den technologischen Standard unserer Produkte ist die enge Entwicklungspartnerschaft mit der Technischen Universität Chemnitz, die im Bereich Antriebs- und Fördertechnik zu den international führenden wissenschaftlichen Einrichtungen zählt. Dafür steht der Name Flexon.

Flexon has been an active player on the drive and conveyor technology market since 1980 and has been committed to focus on client needs in its product range.

*Today Flexon with its brands **eire** and **ecoplus**® is an international, highly specialized service provider in the drive technology sector with products like Roller chains, Agricultural chains, Special chains, Leaf chains, Chain wheels and accessories for all areas of application. Industry, agriculture and many other areas benefit from its high quality and reliable products and its highly flexible service performance.*

The know-how developed over 25 years in the company sectors of research and development, logistics, quality assurance, and services are the solid foundations of the present company employing 100 staff. Flexon has achieved market leadership in the “harvesting machinery” market segment in Europe. Flexon offers the largest product range from high quality Roller chains to Agricultural chains and Chain wheels combined with a comprehensive service program to almost all European original equipment manufacturers.

We have created an optimal logistics procedure for our international clients with our German manufacturing sites Wilnsdorf, responsible for the product sector of Roller chains, Special chains and Chain wheels and Sontra, responsible for the product sector of Agricultural chains, and our sales offices and warehouses in Europe and the USA.

We guarantee our clients the best possible solutions, in particular in sophisticated and difficult tasks set. We are continuously growing in a hard fought market, our consequent commitment to service and performance makes our clients our partners. This is backed by the know-how of several of our specialists in development, manufacture, quality assurance, distribution and service. The technological standard of our products is industry-wide exemplary due to our close co-operation with the Chemnitz Technical University, which belongs to the leading international, scientific institutions in the drive and conveyor technology sector. This is what Flexon stands for.

Inhaltsverzeichnis

Index of contents

Inhalt

Förderketten
Conveyor chains

Förderketten (M-Serie) nach DIN 8167 <i>Conveyor chains (M series) acc. to DIN 8167</i>		7
Förderketten (MT-Serie) nach DIN 8167, Traglaschenkette <i>Conveyor chains (MT series) acc. to DIN 8167, Deep link chain</i>		11
Hohlbolzenketten (MC-Serie) nach DIN 8168 <i>Hollow pin conveyor chains (MC series) acc. to DIN 8168</i>		12
Förderketten (FV-Serie) nach DIN 8165 <i>Conveyor chains (FV series) acc. to DIN 8165</i>		13
Förderketten (FVT-Serie) nach DIN 8165, Traglaschenkette <i>Conveyor chains (FVT series) acc. to DIN 8165, Deep link chain</i>		16
Hohlbolzenketten (FVC-Serie) <i>Hollow pin conveyor chains (FVC series)</i>		17
Förderketten (Z-Serie) <i>Conveyor chains (Z series)</i>		18
Förderketten mit Anbauteilen (Z-Serie) <i>Conveyor chains with attachments (Z series)</i>		19
Förderketten (ZE-Serie), Traglaschenkette <i>Conveyor chains (ZE series), Deep link chain</i>		20
Hohlbolzenketten (ZC-Serie) <i>Hollow pin conveyor chains (ZC series)</i>		21
Förderketten nach Werksnorm <i>Conveyor chains acc. to Industry standard</i>		22
Förderketten mit Anbauteilen nach Werksnorm <i>Conveyor chains with attachments acc. to Industry standard</i>		24
Tragförderkette mit beidseitigen Führungsblöcken <i>Deep link conveyor chains with side guides</i>		30
Tragförderketten mit Sonderlaschen <i>Deep link conveyor chains with special link plates</i>		31
Förderketten mit Anbauteilen <i>Conveyor chains with attachments</i>		32

Inhaltsverzeichnis

Index of contents

Kardanketten für Kreisförderer <i>Cardan chains for Overhead and Floor conveyors</i>		33
Kratzer-Ketten nach DIN 8167 und DIN 8165 (M + FV Serie) <i>Scraper conveyor chains acc. to DIN 8167 and DIN 8165 (M + FV series)</i>		34
Kratzer-Ketten nach Werksnorm <i>Scraper conveyor chains acc. to Industry standard</i>		35
Förderketten mit Sonderbauteilen <i>Conveyor chains with special attachments</i>		36
Rollenketten für die Textilindustrie <i>Roller chains for textile machinery</i>		38
Spezial Ketten für den Folientransport und die Papierindustrie <i>Special chains for plastic film transport and for the paper industry</i>		39
Förderketten für die Papierindustrie <i>Conveyor chains for the paper industry</i>		40
Grabenziehketten <i>Dig chains</i>		41
Rollenketten für Lackier- und Trocknungsanlagen <i>Roller chains for metal decorating systems</i>		42
Plattenbandketten <i>Flat top conveyor chains</i>		45
Förderketten aus Kunststoff Serie CC 600, CC 600 TAB, CC 600 F und aus Temperguss Serie C 600, C 600 TAB <i>Plastic conveyor chains series CC 600, CC 600 TAB, CC 600 F and from Cast iron series C 600, C 600 TAB</i>		46
Förderketten aus Kunststoff Serie CC 600 P, CC 600 TAB P, CC 631 TAB <i>Plastic conveyor chains series CC 600 P, CC 600 TAB P, CC 631 TAB</i>		47
Förderketten aus Kunststoff Serie CC 1400, CC 1400 TAB <i>Plastic conveyor chains series CC 1400, CC 1400 TAB</i>		48
Laschenketten, Ziehbankketten „Gallketten“ <i>Multiple plates bearing pin chains „Gall chains“</i>		49
Buchsenketten nach amerik. Norm <i>Hoisting rollerless chains acc. to American standard</i>		50

Inhaltsverzeichnis

Index of contents

Förderketten für Spezialanwendung
Conveyor chains for special application

Förderketten für die Holzindustrie <i>Conveyor chains and attachments for the Timber Industry</i>		52
Verzahnte Laschen für Rollenketten nach DIN 8187 und 8188 <i>Saw tooth plates for Roller chains acc. to DIN 8187 and 8188</i>		54
Förderketten mit verzahnten Laschen nach Werksnorm <i>Conveyor chains with saw tooth plates acc. to Industry standard</i>		59
Traglaschenkette mit verzahnten Laschen <i>Saw tooth chains (Timber industry)</i>		60
Rollenketten mit aufvulkanisiertem Gummiprofil <i>Roller chains with vulcanised elastomer profiles</i>		61
Rollenketten mit Sonderanbauteilen, U-Bügel U1 und U2 <i>Roller chains with U type attachments</i>		67
Rollenketten mit Sonderanbauteilen, U-Bügel U2 mit 2 Bohrungen <i>Roller chains with U type attachments U2 with 2 holes</i>		68
Rollenketten mit Traglaschen aus Kunststoff <i>Roller chains with Plastic conveyor links</i>		69
Rollenketten mit Kunststoff-Rollen <i>Roller chains with Plastic rollers</i>		71
Rollenketten mit Tragplatten aus Kunststoff (Fortsetzung) <i>Roller chains with Plastic conveyor links</i>		72
Rollenketten mit Traglaschen aus Kunststoff (Transfer-Kette) <i>Roller chains with Plastic Top plates (Transfer chain)</i>		73



Förderketten (M-Serie) nach DIN 8167

Conveyor chains (M series) acc. to DIN 8167

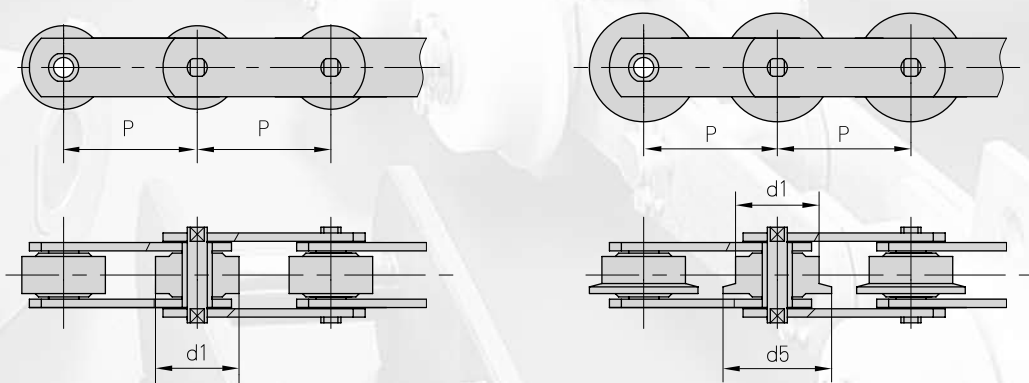
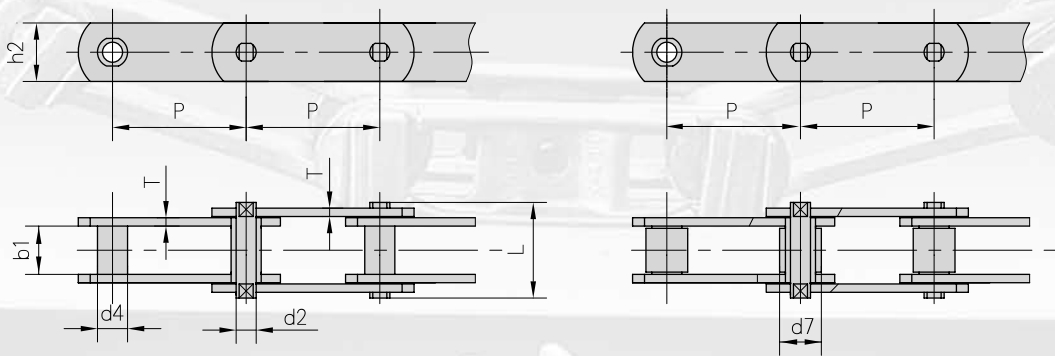



Förderketten (M-Serie) nach DIN 8167

Conveyor chains (M series) acc. to DIN 8167

Flexon ISO Ref.	Teilung								Rollen Ø			Buchsen Ø
	Pitch								Roller diameter			Bush diameter
	P								d1 max	d7 max	d5 max	d4 max
	mm								mm	mm	mm	mm
M20	*40,0	50,0	63,0	80,0	100,0	125,0	160,0		25,0	12,50	32,00	9,0
M28	*50,0	63,0	80,0	100,0	125,0	160,0	200,0		30,0	15,00	36,00	10,0
M40	63,0	80,0	100,0	125,0	160,0	200,0	250,0		36,0	18,00	42,00	12,5
M56	*63,0	80,0	100,0	125,0	160,0	200,0	250,0		42,0	21,00	50,00	15,0
M80	80,0	100,0	125,0	160,0	200,0	250,0	315,0		50,0	25,00	60,00	18,0
M112	*80,0	100,0	125,0	160,0	200,0	250,0	315,0	400,0	60,0	30,00	70,00	21,0
M160	*100,0	125,0	160,0	200,0	250,0	315,0	400,0	500,0	70,0	36,00	85,00	25,0
M224	*125,0	160,0	200,0	250,0	315,0	400,0	500,0	630,0	85,0	42,00	100,00	30,0
M315	*160,0	200,0	250,0	315,0	400,0	500,0	630,0		100,0	50,00	120,00	36,0
M450	200,0	250,0	315,0	400,0	500,0	630,0	800,0		120,0	60,00	140,00	42,0

Flexon ISO Ref.	Lichte Weite	Bolzen Ø	Bolzen- länge	Laschen- höhe	Laschen- dicke	min. Bruchkraft	Durchschn. Bruchlast
	<i>Width between inner plates</i>	<i>Pin diameter</i>	<i>Pin length</i>	<i>Plate depth</i>	<i>Plate thick- ness</i>	<i>Ultimate tensile strength</i>	<i>Average tensile strength</i>
	b1 min	d2 max	L max	h2 max	T max	Q min	Q0
	mm	mm	mm	mm	mm	kN/LB	kN
M20	16,0	6,0	35,0	19,0	2,5	20,0/4545	25,0
M28	18,0	7,0	40,0	21,0	3,0	28,0/6364	35,0
M40	20,0	8,5	45,0	26,0	3,5	40,0/9091	50,0
M56	24,0	10,0	52,0	31,0	4,0	56,0/12727	70,0
M80	28,0	12,0	62,0	36,0	5,0	80,0/18182	100,0
M112	32,0	15,0	73,0	41,0	6,0	112,0/25454	140,0
M160	37,0	18,0	85,0	51,0	7,0	160,0/36364	200,0
M224	43,0	21,0	98,0	62,0	8,0	224,0/50909	280,0
M315	48,0	25,0	112,0	72,0	10,0	315,0/71591	393,7
M450	56,0	30,0	135,0	82,0	12,0	450,0/102272	562,5

* Ausführung als Buchsenkette oder mit Schonrolle
Type as bush chain or with small rollers



Förderketten (M-Serie) nach DIN 8167

Conveyor chains (M series) acc. to DIN 8167

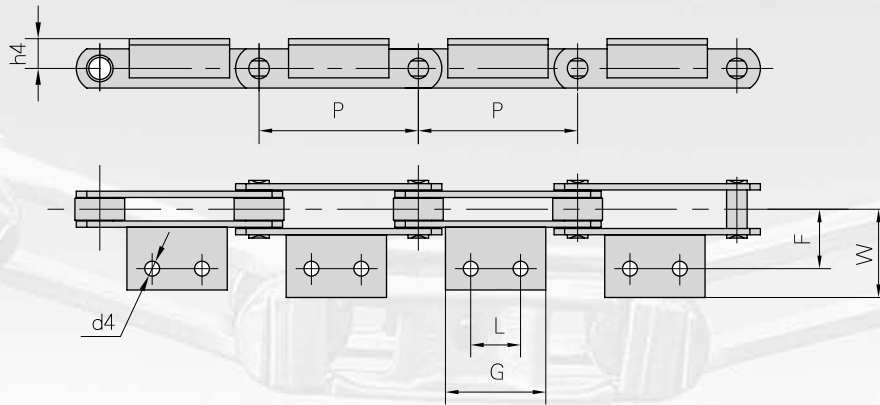

Flexon ISO Ref.	P	L	G	d4	F	W	h4
	mm	mm	mm	mm	mm	mm	mm
M20	40,0	-	14,0	6,6	27,0	40,0	16,0
	50,0	-	14,0				
	63,0	20,0	35,0				
	80,0	35,0	50,0				
M28	50,0	-	20,0	9,0	32,0	47,0	20,0
	63,0	-	20,0				
	80,0	25,0	45,0				
	100,0	40,0	60,0				
M40	63,0	-	31,0	9,0	35,0	50,0	25,0
	80,0	20,0	45,0				
	100,0	40,0	60,0				
	125,0	65,0	85,0				
M56	63,0	-	22,0	11,0	44,0	61,0	30,0
	80,0	-	30,0				
	100,0	25,0	50,0				
	125,0	50,0	75,0				
	160,0	85,0	110,0				
M80	80,0	-	30,0	11,0	48,0	65,0	35,0
	100,0	25,0	50,0				
	125,0	50,0	75,0				
	160,0	85,0	110,0				
	200,0	125,0	150,0				

Förderketten (M-Serie) nach DIN 8167

Conveyor chains (M series) acc. to Din 8167

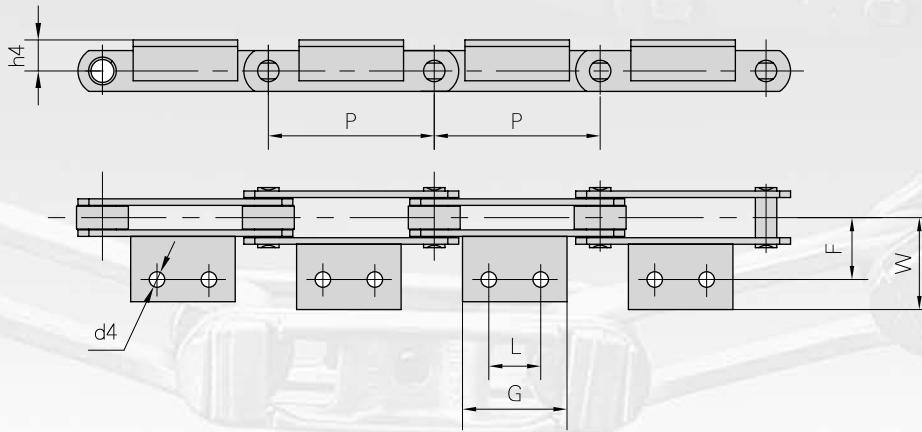

Flexon ISO Ref.	P	L	G	d4	F	W	h4
	mm	mm	mm	mm	mm	mm	mm
M112	80,0	-	28,0	14,0	55,0	80,0	40,0
	100,0	-	40,0				
	125,0	35,0	65,0				
	160,0	65,0	95,0				
	200,0	100,0	130,0				
M160	100,0	-	30,0	14,0	62,0	85,0	45,0
	125,0	25,0	50,0				
	160,0	50,0	80,0				
	200,0	85,0	115,0				
	250,0	145,0	175,0				
M224	125,0	-	35,0	18,0	70,0	100,0	55,0
	160,0	-	60,0				
	200,0	65,0	100,0				
	250,0	125,0	160,0				
	315,0	190,0	230,0				
M315	160,0	-	35,0	18,0	80,0	115,0	65,0
	200,0	50,0	85,0				
	250,0	100,0	140,0				
	315,0	155,0	190,0				
	400,0	155,0	205,0				



Förderketten (MT-Serie) nach DIN 8167, Traglaschenkette

Conveyor chains (MT series) acc. to DIN 8167, Deep link chain

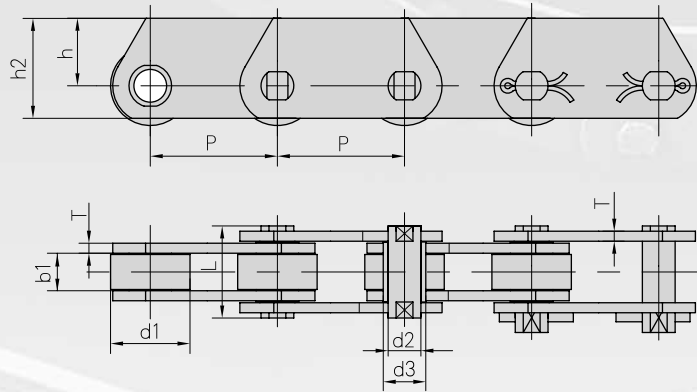

Flexon DIN Ref.	Teilung					Rollen Ø	Bolzen Ø	Buchsen Ø	Laschen dicke
	Pitch					Roller diameter	Pin diameter	Bush diameter	Plate thickness
	P					d1 max	d2 max	d3 max	T max
mm									
MT20	40,0	50,0	63,0	80,0	100,0	25,0	6,0	9,0	2,5
MT28	50,0	63,0	80,0	100,0	125,0	30,0	7,0	10,0	3,0
MT40	63,0	80,0	100,0	125,0	160,0	36,0	8,5	12,5	3,5
MT56	63,0	80,0	100,0	125,0	160,0	42,0	10,0	15,0	4,0
MT80	80,0	100,0	125,0	160,0	200,0	50,0	12,0	18,0	5,0
MT112	80,0	100,0	125,0	160,0	200,0	60,0	15,0	21,0	6,0
MT160	100,0	125,0	160,0	200,0	250,0	70,0	18,0	25,0	7,0
MT224	125,0	160,0	200,0	250,0	315,0	85,0	21,0	30,0	8,0
MT315	160,0	200,0	250,0	315,0	400,0	100,0	25,0	36,0	10,0
MT450	200,0	250,0	315,0	400,0	500,0	120,0	30,0	42,0	12,0

Flexon DIN Ref.	Lichte Weite	Bolzen- länge	Laschen- höhe		min. Bruchkraft	
	Width between inner plates	Pin length	Plate depth		Ultimate tensile strength	
	b1 min	L max	h2 max	h max	Q min	*Q min
mm						
					kN/LB	kN/LB
MT20	16,0	35,0	25,0	16,0	20,0/4545	32,0/7270
MT28	18,0	40,0	30,0	20,0	28,0/6364	42,0/9545
MT40	20,0	45,0	35,0	22,5	40,0/9091	60,0/13635
MT56	24,0	52,0	45,0	30,0	56,0/12727	85,0/19318
MT80	28,0	62,0	50,0	32,5	80,0/18182	125,0/28408
MT112	32,0	73,0	60,0	40,0	112,0/25454	175,0/39768
MT160	37,0	85,0	70,0	45,0	160,0/36364	260,0/59090
MT224	43,0	98,0	90,0	60,0	224,0/50909	340,0/77272
MT315	48,0	112,0	100,0	65,0	315,0/71591	520,0/118180
MT450	56,0	135,0	120,0	80,0	450,0/102272	700,0/159089

*Q - Höhere Bruchlast durch härtere Laschen Higher breaking load with hardened plates



Hohlbolzenketten (MC-Serie) nach DIN 8168

Hollow pin conveyor chains (MC series) acc. to DIN 8168

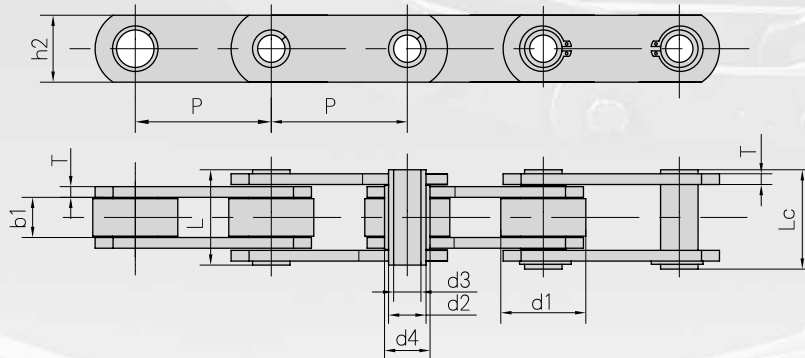

ohne Rollen
without roller

S (mit kleiner Rolle)
S (small roller type)

P (mit großer Rolle)
P (large roller type)

F (mit Spurkranz Rolle)
with F flanged roller type

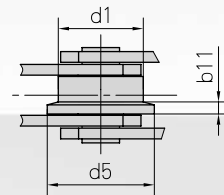
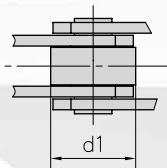
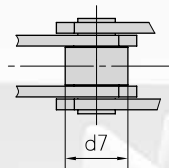
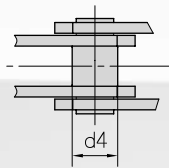

Flexon ISO Ref.	Teilung						Rollen- abmessungen				Buchsen Ø	Laschen höhe
	Pitch						Roller dimension				Bush diameter	Plate depth
	P						d1 max	d7 max	d5 max	b11	d4 max	h2 max
mm						mm	mm	mm	mm	mm	mm	
MC28	63,0	80,0	100,0	125,0	160,0		36,0	25,0	45,0	4,5	17,0	25,0
MC56	80,0	100,0	125,0	160,0	200,0	250,0	50,0	30,0	60,0	5,0	21,0	35,0
MC112	100,0	125,0	160,0	200,0	250,0	315,0	70,0	42,0	85,0	7,0	29,0	50,0
MC224	160,0	200,0	250,0	315,0	400,0	500,0	100,0	60,0	120,0	10,0	41,0	70,0

Flexon ISO Ref.	Lichte Weite	Bolzen Ø		Bolzen- länge		Laschen- dicke	Bruchlast	
	Width between inner plates	Pin diameter		Pin length		Plate thickness	Breaking load	
	b1 min	d2 max	d3 min	L max	Lc max	T max	Q min	*Q min
mm		mm	mm	mm	mm	mm	kN/LB	kN/LB
MC28	20,0	13,0	8,2	36,0	38,5	3,0	28,0/6364	40,0/9091
MC56	24,0	15,5	10,2	45,0	47,5	4,0	56,0/12727	90,0/20454
MC112	32,0	22,0	14,3	62,5	64,3	6,0	112,0/25454	180,0/40908
MC224	43,0	30,0	20,3	83,0	85,5	8,0	224,0/50909	350,0/79544

*Q - Höhere Bruchlast durch härtere Laschen
Higher breaking load with hardened plates



Förderketten (FV-Serie) nach DIN 8165

Conveyor chains (FV series) acc. to DIN 8165

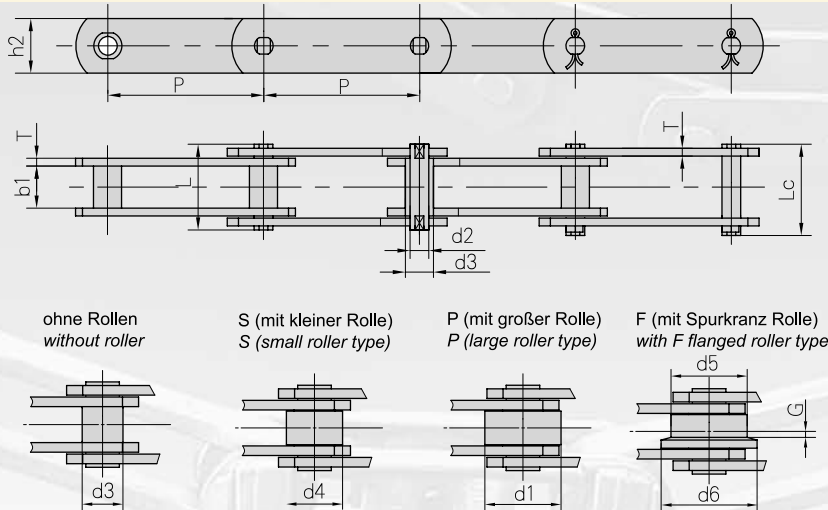

Flexon DIN Ref.	Teilung							Rollen- abmessungen					Buchsen Ø
	Pitch							Roller dimension					Bush diameter
	P							d1 max	d4 max	d5 max	d6 max	G	d3
	mm	mm	mm	mm	mm	mm	mm	mm	mm	mm	mm	mm	mm
FV40	50,0	63,0	80,0	100,0	125,0			32,0	20,0	40,0	50,0	4,0	15,0
FV63	63,0	80,0	100,0	125,0	160,0			40,0	26,0	50,0	63,0	5,0	18,0
FV90	63,0	80,0	100,0	125,0	160,0	200,0	250,0	48,0	30,0	63,0	78,0	6,5	20,0
FV112	100,0	125,0	160,0	200,0	250,0			55,0	32,0	72,0	90,0	7,5	22,0
FV140	100,0	125,0	160,0	200,0	250,0			60,0	36,0	80,0	100,0	9,0	26,0
FV180	125,0	160,0	200,0	250,0	315,0			70,0	42,0	100,0	125,0	13,0	30,0
FV250	160,0	200,0	250,0	315,0	400,0			80,0	50,0	125,0	155,0	15,0	36,0
FV315	160,0	200,0	250,0	315,0	400,0			90,0	60,0	140,0	175,0	18,0	42,0

Flexon DIN Ref.	Lichte Weite	Bolzen Ø	Bolzen- länge		Laschen- höhe	Laschen- dicke	min. Bruchkraft	
	Width between inner plates	Pin diameter	Pin length		Plate depth	Plate thickness	Ultimate tensile strength	
	b1 min	d2 max	L min	Lc max	h2 max	T max	Q min	*Q min
	mm	mm	mm	mm	mm	mm	kN/LB	kN/LB
FV40	18,0	10,0	36,0	39,0	25,0	3,0	40,0/9091	47,0/10681
FV63	22,0	12,0	45,0	48,5	30,0	4,0	63,0/14317	75,0/17045
FV90	25,0	14,0	53,0	56,5	35,0	5,0	90,0/20453	115,0/26136
FV112	30,0	16,0	62,0	66,0	40,0	6,0	112,0/25452	170,0/38636
FV140	35,0	18,0	67,0	71,5	45,0	6,0	140,0/31815	180,0/40908
FV180	45,0	20,0	86,0	92,0	50,0	8,0	180,0/40908	250,0/56817
FV250	55,0	26,0	97,0	103,5	60,0	8,0	250,0/56817	300,0/68181
FV315	65,0	30,0	113,0	126,5	70,0	10,0	315,0/71591	480,0/109089

*Q - Höhere Bruchlast durch härtere Laschen
Higher breaking load with hardened plates



Förderketten (FV-Serie) nach DIN 8165

Conveyor chains (FV series) acc. to DIN 8165

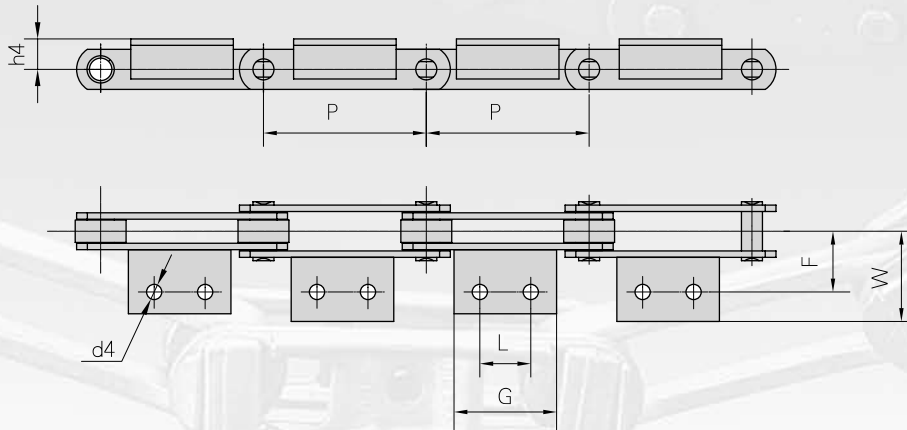

Flexon DIN Ref.	P	L	G	d4	F	W	h4
	mm	mm	mm	mm	mm	mm	mm
FV40	50,0	-	45,0	6,5	25,0	64,0	20,0
	63,0	-	31,0			40,5	
	80,0	25,0	45,0				
	100,0	30,0	50,0				
	125,0	30,0	60,0				
FV63	63,0	-	40,0	8,4	34,0	50,0	30,0
	80,0	25,0	45,0				
	100,0	30,0	50,0				
	125,0	40,0	60,0				
	160,0	50,0	70,0				
FV90	63,0	-	30,0	8,4	40,0	64,0	35,0
	80,0	25,0	45,0				
	100,0	30,0	50,0				
	125,0	40,0	60,0				
	160,0	50,0	70,0				
	200,0	60,0	80,0				
	250,0	65,0	85,0				
FV112	100,0	30,0	50,0	11,0	50,0	70,0	40,0
	125,0	40,0	65,0				
	160,0	50,0	75,0				
	200,0	65,0	90,0				
	250,0	80,0	105,0				



Förderketten (FV-Serie) nach DIN 8165

Conveyor chains (FV series) acc. to DIN 8165

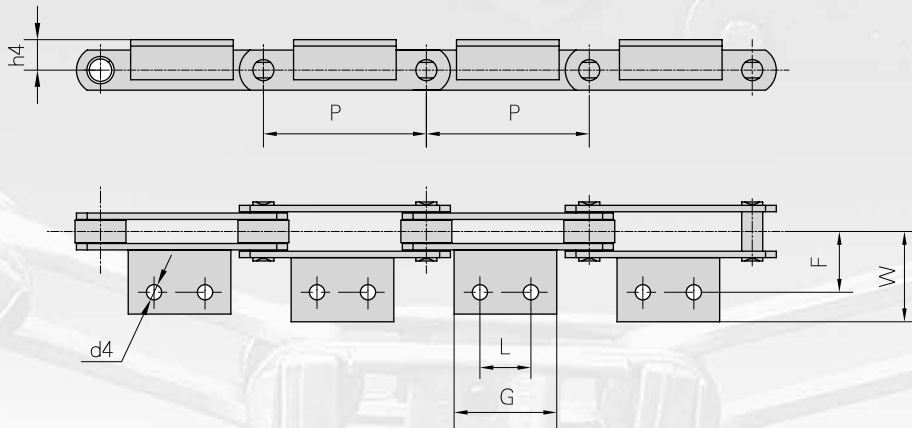

Flexon DIN Ref.	P	L	G	d4	F	W	h4
	mm	mm	mm	mm	mm	mm	mm
FV140	100,0	30,0	55,0	11,0	50,0	81,0	45,0
	125,0	40,0	65,0				
	160,0	50,0	75,0				
	200,0	65,0	90,0				
	250,0	80,0	105,0				
FV180	125,0	35,0	63,0	13,0	64,0	91,0	45,0
	160,0	50,0	80,0				
	200,0	65,0	95,0				
	250,0	80,0	110,0				
	315,0	100,0	130,0				
FV250	160,0	50,0	80,0	14,0	69,0	106,0	55,0
	200,0	65,0	95,0				
	250,0	80,0	110,0				
	315,0	100,0	130,0				
	400,0	100,0	130,0				
FV315	160,0	-	50,0	14,0	85,0	130,0	60,0
	200,0	65,0	95,0				
	250,0	80,0	110,0				
	315,0	100,0	130,0				
	400,0	100,0	130,0				



Förderketten (FVT-Serie) nach DIN 8165, Traglaschenkette

Conveyor chains (FVT series) acc. to DIN 8165, Deep link chain

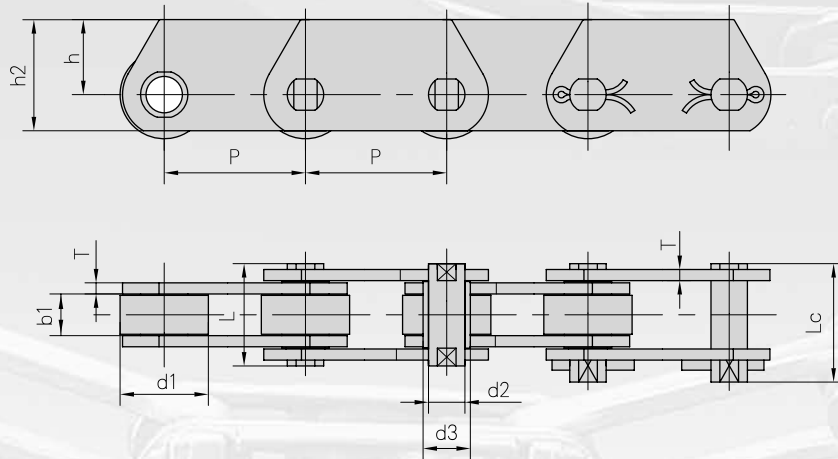

Flexon DIN Ref.	Teilung							Rollen Ø	Bolzen Ø	Buchsen Ø	Laschen dicke
	Pitch							Roller diameter	Pin diameter	Bush diameter	Plate thickness
	P							d1 Ø max	d2 Ø max	d3 Ø max	T max
	mm							mm	mm	mm	mm
FVT40	50,0	63,0	80,0	100,0	125,0			32,0	10,0	15,0	3,0
FVT63	63,0	80,0	100,0	125,0	160,0			40,0	12,0	18,0	4,0
FVT90	63,0	80,0	100,0	125,0	160,0	200,0	250,0	48,0	14,0	20,0	5,0
FVT112	100,0	125,0	160,0	200,0	250,0			55,0	16,0	22,0	6,0
FVT140	100,0	125,0	160,0	200,0	250,0			60,0	18,0	25,0	6,0
FVT180	125,0	160,0	200,0	250,0	315,0			70,0	20,0	30,0	8,0
FVT250	160,0	200,0	250,0	315,0				80,0	26,0	36,0	8,0
FVT315	160,0	200,0	250,0	315,0	400,0			90,0	30,0	42,0	10,0

*Q - Höhere Bruchlast durch härtere Laschen
Higher breaking load with hardened plates

Flexon DIN Ref.	Lichte Weite	Bolzen- länge		Laschen- höhe		min. Bruchkraft	
	Width between inner plates	Pin length		Plate depth		Ultimate tensile strength	
	b1 min	L max	Lc max	h2 max	h max	Q min	Q min
	mm	mm	mm	mm	mm	kN/LB	kN/LB
FVT40	18,0	36,0	39,0	35,0	22,5	40,0/9091	47,0/10681
FVT63	22,0	45,0	48,5	40,0	25,0	63,0/14317	75,0/17045
FVT90	25,0	53,0	56,5	45,0	27,5	90,0/20453	115,0/26136
FVT112	30,0	62,0	66,0	50,0	30,0	112,0/25452	170,0/38636
FVT140	35,0	67,0	71,5	60,0	37,5	140,0/31815	180,0/40908
FVT180	45,0	86,0	92,0	70,0	45,0	180,0/40908	250,0/56817
FVT250	55,0	97,0	103,5	80,0	50,0	250,0/56817	300,0/68181
FVT315	65,0	113,0	126,5	90,0	55,0	315,0/71591	480,0/109089

ELITE Hohlbolzenketten (FVC-Serie)

Hollow pin conveyor chains (FVC series)

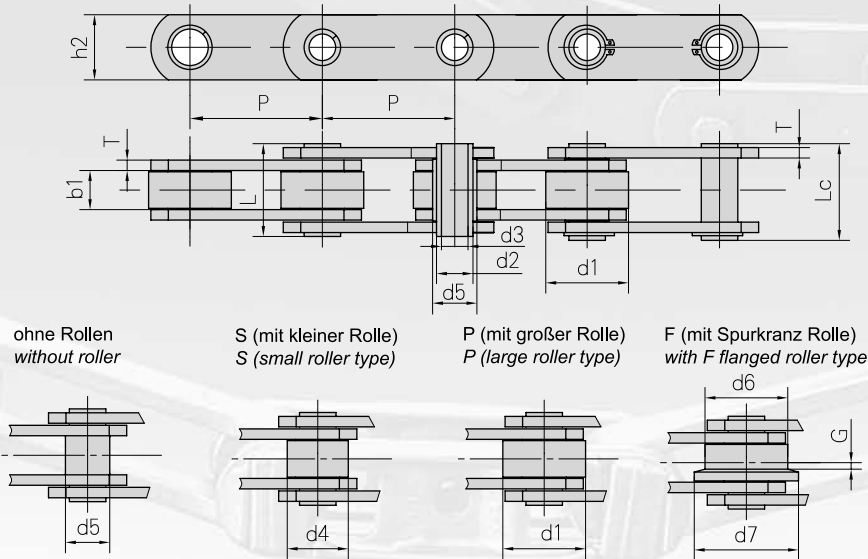

Flexon DIN Ref.	Teilung							Rollen abmessungen				
	Pitch							Roller dimension				
	P							d1 Ø max	d4 Ø max	d6 Ø max	d7 Ø max	G
	mm	mm	mm	mm	mm	mm	mm	mm	mm	mm	mm	mm
FVC63	63,0	80,0	100,0	125,0	160,0			40,0	26,0	50,0	63,0	5,0
FVC90	63,0	80,0	100,0	125,0	160,0	200,0	250,0	48,0	30,0	63,0	78,0	6,5
FVC112	100,0	125,0	160,0	200,0	250,0			55,0	32,0	72,0	90,0	7,5
FVC140	100,0	125,0	160,0	200,0	250,0			60,0	36,0	80,0	100,0	9,0
FVC180	125,0	160,0	200,0	250,0	315,0			70,0	42,0	100,0	125,0	13,0
FVC250	160,0	200,0	250,0	315,0	400,0			80,0	50,0	125,0	155,0	15,0
FVC315	160,0	200,0	250,0	315,0	400,0			90,0	60,0	140,0	175,0	18,0

Flexon DIN Ref.	Lichte Weite	Bolzen Ø		Buchsen Ø	Bolzen- länge		Laschen- dicke	Laschen- höhe	min. Bruchkraft
	Width between inner plates	Pin diameter		Bush diameter	Pin length		Plate thickness	Plate depth	Ultimate tensile strength
	b1 min	d2 Ø max	d3 Ø min	d5 Ø max	L max	Lc max	T max	h2 max	Q min
	mm	mm	mm	mm	mm	mm	mm	mm	kN/LB
FVC63	22,0	12,0	8,0	18,0	45,0	50,5	4,0	30,0	46,0/10454
FVC90	25,0	14,0	10,0	20,0	53,0	56,5	5,0	35,0	73,0/16590
FVC112	30,0	16,0	11,0	22,0	62,0	63,0	6,0	40,0	90,0/20454
FVC140	35,0	18,0	12,0	26,0	67,0	68,5	6,0	45,0	110,0/25000
FVC180	45,0	20,0	14,0	30,0	86,0	88,0	8,0	50,0	145,0/32954
FVC250	55,0	26,0	18,0	36,0	97,0	103,5	8,0	60,0	215,0/48863
FVC315	65,0	30,0	20,0	42,0	117,0	121,5	10,0	70,0	295,0/67044



Förderketten (Z-Serie)

Conveyor chains (Z series)

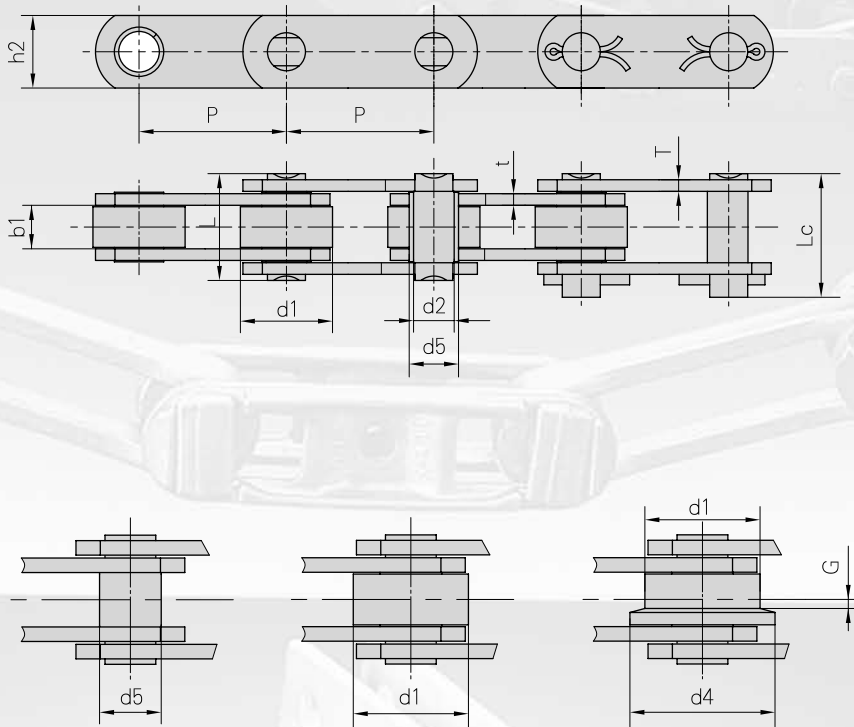

Flexon Chain No.	Teilung							Rollen-abmessungen			Buchsen Ø
	Pitch							Roller dimension			Bush diameter
	P							d1 Ø max	d4 Ø max	G	d5 max
	mm	mm	mm	mm	mm	mm	mm	mm	mm	mm	mm
Z40	50,8	63,5	76,2	88,9	101,6	127,0	152,4	31,75	40,0	2,5	17,0
Z100	76,2	88,9	101,6	127,0	152,4	177,8	203,2	47,50	60,0	3,5	23,0
Z160	101,6	127,0	152,4	177,8	203,2	228,6	254,0	66,70	82,0	3,5	33,0
Z300	152,4	177,8	203,2	254,0	304,8			88,90	114,0	8,5	38,0

Flexon Chain No.	Lichte Weite	Bolzen Ø	Laschen-höhe	Bolzen-länge		Laschen-dicke	Bruchlast	
	Width between inner plates	Pin diameter	Plate depth	Pin length		Plate thickness	Breaking load	
	bi min	d2 Ø max	h2 min	L max	Lc max	t/T min	Q min	*Q min
	mm	mm	mm	mm	mm	kN/LB		kN/LB
Z40	15,0	14,0	25,0	37,0	40,5	4,0	40,0/9091	50,0/11362
Z100	19,0	19,0	40,0	45,0	50,5	5,0/4,0	100,0/22725	130,0/29540
Z160	26,0	26,9	50,0	58,0	63,5	7,0/5,0	156,0/35451	200,0/45454
Z300	38,0	32,0	60,0	84,0	94,0	10,0/8,0	300,0/68175	380,0/86362



Förderketten mit Anbauteilen (Z-Serie)

Conveyor chains with attachments (Z series)

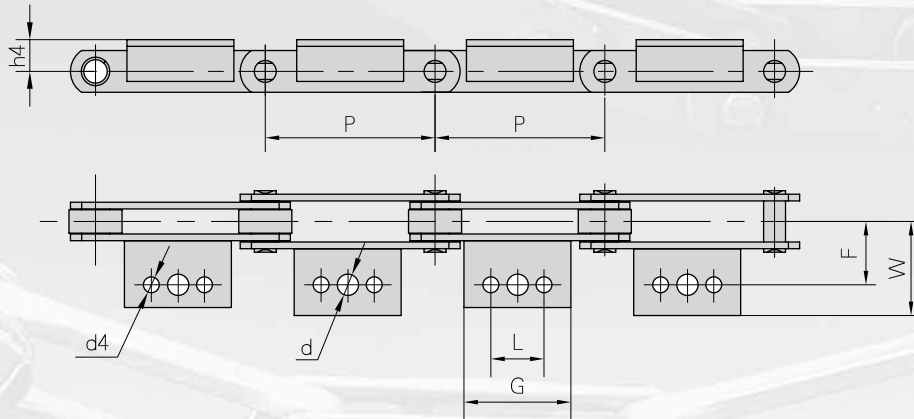

Flexon Chain No.	Symbol	P	L	G	d	d4	F	W	h4	
		mm	mm	mm	mm	mm	mm	mm	mm	
Z40	Δ	50,8	-	45,0	10,7	-	38,1	64,5	19,0	
	Δ	63,5	22,2	43,0		9,3		56,0		
	▲	76,2						68,0		
	▲	88,9	38,1	50,0				56,0		
	▲	101,6		64,0				55,0		
	▲	127,0	57,2	84,0				56,0		
	▲	152,4								
Z100	Δ	76,2	-	30,0	14,0	-	44,5	65,0	32,0	
	Δ	88,9								
	▲	101,6	31,8	64,0		10,5				
	Δ ■	127,0	57,2	84,0						
	▲	152,4		114,5						
	Δ ■	177,8	80,0	110,0						
	Δ ■	203,2								
Z160	Δ	101,6	-	35,0	15,5	-	54,0	77,0	38,0	
	Δ ■	127,0	31,7	56,0		12,3				
	Δ ■	152,4	57,2	84,0						
	Δ ■	177,8								
	Δ ■	203,2	100,0	130,0						
	Δ ■	228,6		150,0						
	Δ ■	254,0	135,0	170,0						
Z300	Δ	152,4	38,1	70,0	17,0	14,0	73,0	100,0	51,0	
	Δ	177,8								
	Δ ■	203,2	76,2	100,0						
	Δ ■	254,0	90,0	152,4						
	Δ ■	304,8	190,0	225,0						

Δ Ketteneinbauteil mit einem Loch
Attachment with 1 hole

■ Ketteneinbauteil mit zwei Löchern
Attachment with 2 holes

▲ Ketteneinbauteil mit drei Löchern
Attachment with 3 holes

Förderketten (ZE-Serie), Traglaschenkette

Conveyor chains (ZE series), Deep link chain

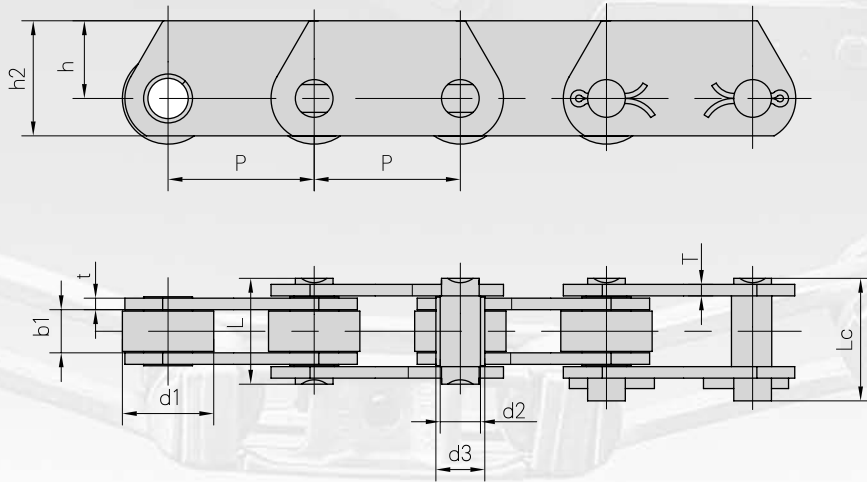

Flexon Chain No.	Teilung							Rollen Ø	Bolzen Ø	Buchsen Ø
	Pitch							Roller diameter	Pin diameter	Bush diameter
	P							d1 max	d2 max	d3 max
	mm							mm	mm	mm
ZE40	50,8	63,5	76,2	88,9	101,6	127,0	152,4	31,75	14,0	17,0
ZE100	76,2	88,9	101,6	127,0	152,4	177,8	203,2	47,50	19,0	23,0
ZE160	101,6	127,0	152,4	177,8	203,2	228,6	254,0	66,70	26,9	33,0
ZE300	152,4	177,8	203,2	254,0	304,8			88,90	32,0	38,0

Flexon Chain No.	Lichte Weite	Bolzenlänge		Laschenhöhe		Laschen- dicke	Bruchlast	
	Width between inner plates	Pin length		Plate depth		Plate thick- ness	Breaking load	
	b1 min	L max	Lc max	h2 max	h max	t/T max	Q min	*Q min
	mm	mm	mm	mm	mm	mm	kN/LB	kN/LB
ZE40	15,0	37,0	40,5	40,0	27,0	4,0	40,0/9091	60,0/13636
ZE100	19,0	45,0	50,5	50,0	30,0	5,0/4,0	100,0/22725	160,0/36360
ZE160	26,0	58,0	63,5	70,0	45,0	7,0/5,0	160,0/36360	200,0/45454
ZE300	38,0	84,0	94,0	90,0	60,0	10,0/8,0	300,0/68175	380,0/86362

*Q - Höhere Bruchlast durch härtere Laschen
Higher breaking load with hardened plates

ELITE Hohlbolzenketten (ZC-Serie)

Hollow pin conveyor chains (ZC series)

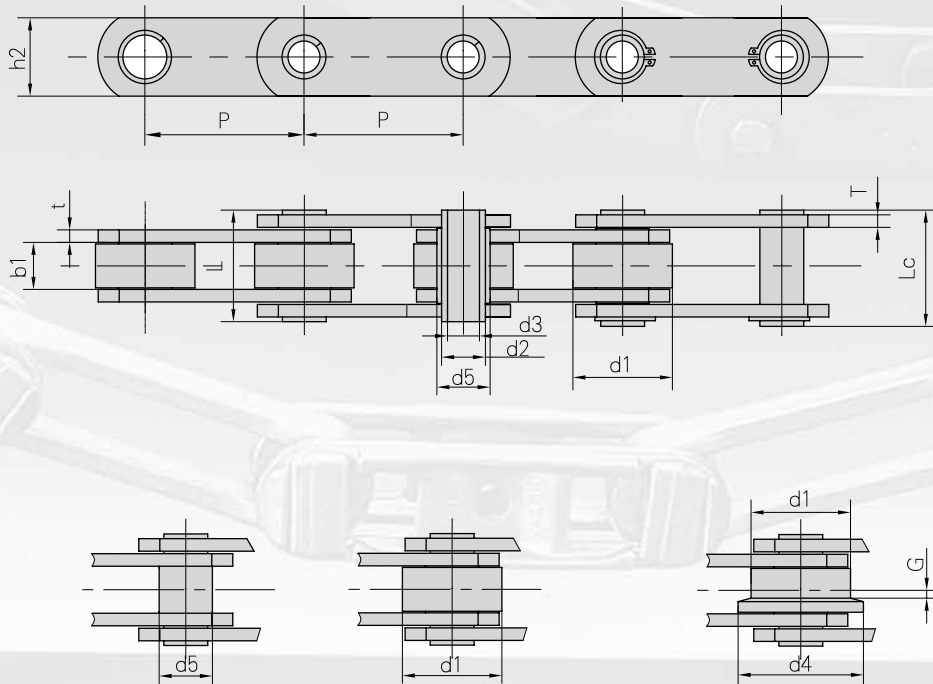

Flexon Chain No.	Teilung							Rollen- abmessungen			Buchsen Ø	Laschen höhe
	Pitch							Roller dimension			Bush diameter	Plate depth
	P							d1 max	d4 max	G	d5 max	h2 max
	mm							mm	mm	mm	mm	mm
ZC21	38,1	50,8	63,5	76,2				25,40			11,0	18,0
ZC40	50,8	63,5	76,2	88,9	101,6	127,0	152,4	31,75	40,0	2,5	17,0	25,0
ZC60	76,2	88,9	101,6	127,0	152,4	177,8	203,2	47,50	60,0	3,5	23,0	40,0
ZC150	101,6	127,0	152,4	177,8	203,2	228,6	254,0	66,70	82,0	4,0	33,0	50,0
ZC300	152,4	177,8	203,2	254,0	304,8			88,90	114,0	8,5	38,0	60,0

Flexon Chain No.	Lichte Weite	Bolzen Ø		Bolzen- länge		Laschen- dicke	Bruchlast	
	Width between inner plates	Pin diameter		Pin length		Plate thick- ness	Breaking load	
	b1 min	d2 max	d3 max	L max	Lc max	t/T max	Q min	*Q min
	mm	mm	mm	mm	mm	mm	kN/LB	kN/LB
ZC21	12,7	9,0	6,5	26,0	27,5	2,5	21,0/4772	
ZC40	15,0	14,0	10,2	36,4	37,7	4,0	40,0/9091	50,0/11362
ZC60	19,0	19,0	13,2	45,0	46,0	5,0/4,0	60,0/13636	120,0/27270
ZC150	26,0	26,9	20,2	58,0	60,5	7,0/5,0	150,0/34087	190,0/43177
ZC300	38,0	32,0	22,5	83,0	85,0	10,0/8,0	300,0/68175	380,0/86362

*Q - Höhere Bruchlast durch härtere Laschen
Higher breaking load with hardened plates



Förderketten nach Werksnorm

Conveyor chains acc. to Industry standard

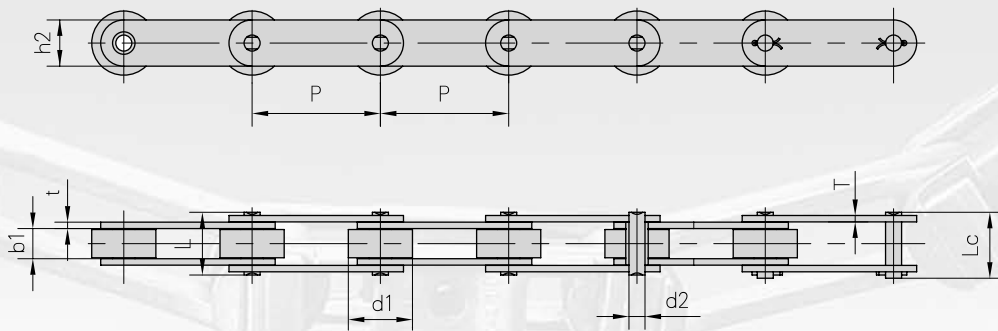

Flexon Chain No.	Teilung	Rollen Ø	Lichte Weite	Bolzen Ø	Bolzen- länge		Höhe Innen- lasche Inner plate depth	Laschen- dicke	min. Bruchkraft	Durchschn. Bruchlast	Gewicht per meter
	Pitch	Roller diameter	Width between innerplates	Pin diameter	Pin length		h2 max	t/T	Ultimate tensile strength	Average tensile strength	Weight per meter
	P mm	d1 max mm	b1 min mm	d2 max mm	L max mm	Lc max mm	mm	mm	Q min kN/LB	Q0 kN	q kg/m
P42	42,01	22,23	25,40	11,10	55,25		28,50	4,8	100,0/22727	110,0	5,36
P42F1	42,01	22,23	25,40	11,10	50,30	54,3	28,50	4,8	90,0/20454	99,0	5,26
P44.45F1	44,45	22,23	24,70	11,10	62,00	65,5	32,00	6,7	110,0/25000	121,0	7,30
P50	50,00	25,40	25,40	14,63	54,30	57,8	40,00	5,0	100,0/22727	110,0	7,50
P50F1	50,00	29,21	30,99	17,81	66,00		42,20	7,0	210,0/47726	231,0	9,68
P50.8F1	50,80	30,00	10,00	11,70	30,20	34,5	26,04	4,0	83,0/18863	91,3	2,60
P63.5	63,50	19,05	18,90	9,53	44,60	47,2	28,60	5,0	86,7/19704	95,4	3,77
P76.2F2	76,20	50,00	26,00	24,00	69,60	74,7	59,50	8,0	350,0/79544	385,0	19,00
P80F1	80,00	42,00	24,00	15,00	55,00	60,0	60,00	6,0	250,0/56817	275,0	11,90
P80F5	80,00	28,00	34,00	16,00	68,00	72,0	45,00	5,0/8,0	190,0/43181	209,0	8,80
P80F6	80,00	30,00	32,00	15,00	58,60	62,6	60,00	5,0	98,0/22272	108,0	9,75
P80F10	80,00	42,00	22,00	15,00	53,00	58,0	60,00	6,0	250,0/56817	275,0	11,40
P101.6F4	101,60	66,70	25,40	26,90	59,20	80,0*	51,00	7,1/5,1	134,0/30454	147,4	15,70
P125F1	125,00	50,00	55,00	26,00	110,00		60,00	8,0	300,0/68181	330,0	13,53
P150.5	150,50	38,12	40,81	16,02	83,50	88,0	44,23	8,5	250,0/56817	275,0	10,00
P152F5	152,40	66,70	25,40	26,90	59,20	80,0*	50,00	7,1/5,1	134,0/30454	147,4	12,10
P152F10	152,40	57,20	37,10	15,90	76,80	87,0	44,50	7,9	190,0/43181	209,0	11,29
P200F10	200,00	100,00	47,00	25,00	103,50		72,00	10,0	308,7/70158	339,6	28,30



Förderketten nach Werksnorm

Conveyor chains acc. to Industry standard

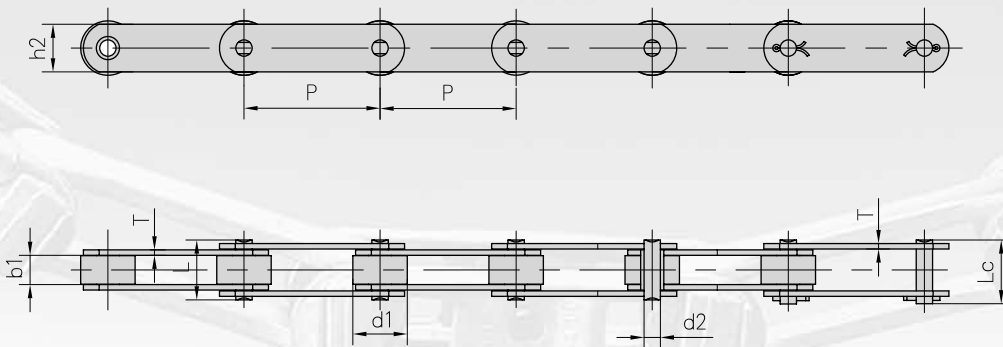

Flexon	Teilung	Rollen Ø	Lichte Weite	Bolzen Ø	Bolzen-länge		Laschen-höhe	Laschen-dicke	min. Bruchkraft	Durchschn. Bruchlast	Gewicht per meter
Chain No.	Pitch	Roller diameter	Width between inner plates	Pin diameter	Pin length		Plate depth	Plate thickness	Ultimate tensile strength	Average tensile strength	Weight per meter
	P	d1 max	b1 min	d2 max	L max	Lc max	h2 max	T max	Q min	Q0	q
	mm	mm	mm	mm	mm	mm	mm	mm	kN/LB	kN	kg/m
M100-P-80	80,0	47,5	31,4	15,9	71,2	76,0	40,0	8,0	100,0/22727	110,0	12,36
M112F2-P-125	125,0	55,0	50,0	16,0	87,1	91,6	40,0	7,2	112,0/25454	123,0	13,35
M160F1-P-100	100,0	36,0	36,0	18,0	76,0	80,0	40,0	7,0	160,0/36364	176,0	9,42
M224F3-P-160	160,0	80,0	30,0	21,0	81,0		60,0	8,0	224,0/50909	246,0	17,34



Förderketten mit Anbauteilen nach Werksnorm

Conveyor chains with attachments acc. to Industry standard

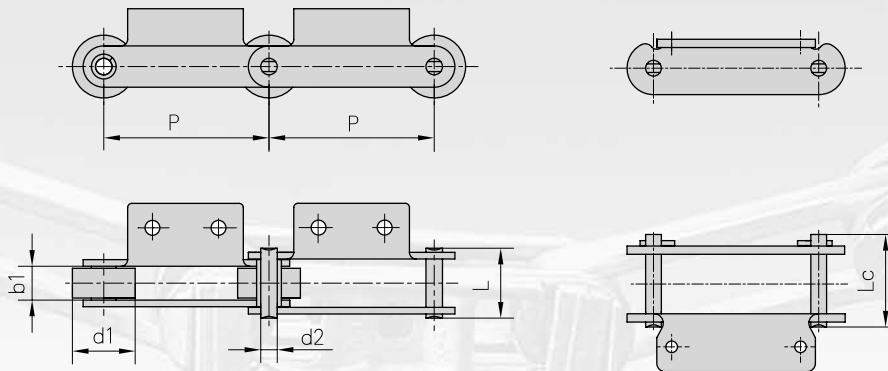

Flexon	Teilung	Rollen \varnothing	Lichte Weite	Bolzen \varnothing	Bolzenlänge		min. Bruchkraft	Durchschn. Bruchlast	Gewicht per meter
Chain No.	Pitch	Roller diameter	Width between inner plates	Pin diameter	Pin length		Ultimate tensile strength	Average tensile strength	Weight per meter
	P	d1 max	b1 min	d2 max	L max	Lc max	Q min	Q0	q
	mm	mm	mm	mm	mm	mm	kN/LB	kN	kg/m
*P28	28,575	11,68	16,00	7,87	32,4		50,0/11364	55,0	2,66
* P28F1	28,575	11,68	16,13	7,87	32,4		50,0/11364	55,0	2,60
P38.1 F2	38,100	22,50	13,00	8,00	29,5	33,3	40,0/9091	44,0	2,42
P42.5	42,500	15,88	15,75	7,92	32,7	36,5	56,7/12886	62,0	3,40
P76.2F1	76,200	31,75	15,00	14,20	44,2		60,0/13636	66,0	4,45
P78.11 F8	78,110	31,80	37,10	15,00	83,5		100,0/22727	110,0	12,05
P80F4	80,000	30,00	15,00	13,90	42,5	46,5	86,0/19545	95,0	3,97
P100F1	100,000	42,00	23,00	9,53	52,0	54,3	86,7/19704	95,0	6,06
P100F2	100,000	36,00	18,00	9,53	47,0	49,3	86,7/19704	95,0	4,60
P100F3	100,000	29,00	30,00	14,50	71,0		95,0/21591	105,0	9,46
P100F4	100,000	40,00	22,00	11,30	53,5		65,0/14773	72,0	5,13
P100F5	100,000	22,20	22,00	11,30	53,5		65,0/14773	72,0	3,90
P100F12	100,000	45,00	37,00	12,00	64,0	67,0	150,0/34091	165,0	10,30
P100F15	100,000	38,00	25,80	10,70	57,0		45,0/10227	50,0	5,25
*P101.6F1	101,600	25,00	55,00	16,00	110,0		60,0/13636	66,0	11,90
P101.6F9	101,600	31,75	15,00	14,20	44,2		66,7/15159	73,0	8,40
MSR4013A2	101,600	22,23	25,20	10,60	57,2		106,7/24250	117,0	4,29
P120	120,000	50,00	28,00	12,00	54,0	58,0	160,0/36363	176,0	8,14

*Buchsenketten: In der Tabelle zeigt d1 den Außen \varnothing der Buchse
 *Bushing chain: d1 in the table indicate the external diameter of the bushing



Förderketten mit Anbauteilen nach Werksnorm

Conveyor chains with attachments acc. to Industry standard

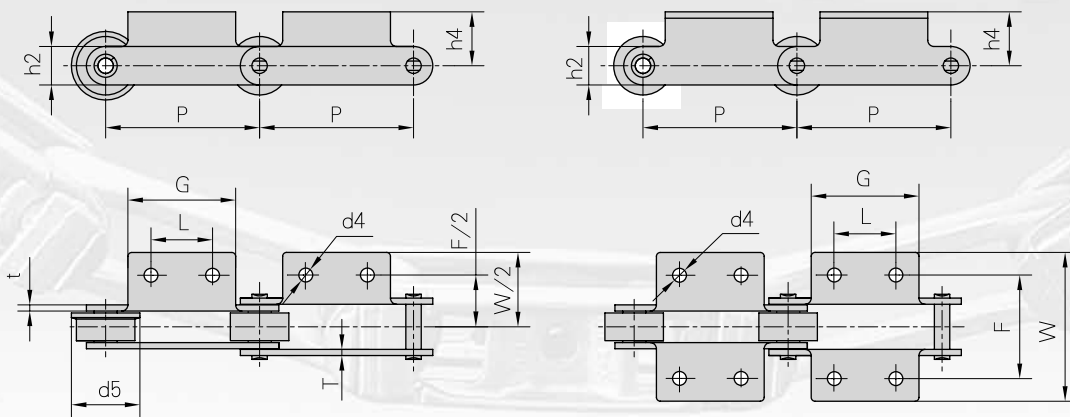

Flexon Chain No.	P	L	G	F	W	h4	h2	d4	t/T	d5
	mm	mm	mm	mm	mm	mm	mm	mm	mm	mm
*P28	28,575	28,58	51,0	46,74	61,20	13,70	22,23	8,75	3,10	
*P28F1	28,575	28,58	50,8	46,80	61,86	12,70	22,23	9,02	3,10	
P38.1 F2	38,100		28,0	56,00	76,00	17,20	19,00	9,00	3,00	
P42.5	42,500	19,00	38,0	53,50	70,00	19,50	22,00	7,00	3,25	
P76.2F1	76,200	31,00	58,0	75,40	107,00	21,25	29,00	10,50	4,50	
P78.11 F8	78,110	30,00	65,0	120,00	150,00	35,00	38,10	12,00	7,90	
P80F4	80,000	40,00	70,2	57,40	87,40	22,95	27,10	8,50	5,60/4,15	
P100F1	100,000	78,00	96,0	73,00	103,00	17,50	32,00	7,00	5,00	
P100F2	100,000	40,00	70,0	68,00	98,00	17,50	32,00	9,00	5,00	
P100F3	100,000	40,00	70,0	100,00	128,00	28,00	38,10	12,00	6,00	
P100F4	100,000	40,00	65,0	70,00	94,00	22,00	32,00	10,00	4,50	
P100F5	100,000	40,00	65,0	70,00	94,00	22,00	32,00	10,00	4,50	
P100F12	100,000	60,00	90,0	98,00	128,00	34,00	40,00	11,50	5,00	64,0
P100F15	100,000	29,85	65,0	75,00	115,60	20,00	28,00	9,00	4,80	
*P1 01.6F1	101,600	44,00	73,0	136,00	165,00	30,00	40,00	11,00	10,00	
P101.6F9	101,600	31,00	65,0	75,40	107,00	21,25	29,00	10,50	4,50	
MSR4013A2	101,600	30,20	63,5	70,20	109,72	20,60	28,50	8,64	4,80	
P120	120,000	50,00	75,0	82,00	119,60	20,00	40,00	7,00	5,00	59,0

*Buchsenketten: In der Tabelle zeigt d1 den AußenØ der Buchse

*Bushing chain: d1 in the table indicate the external diameter of the bushing



Förderketten mit Anbauteilen nach Werksnorm

Conveyor chains with attachments acc. to Industry standard

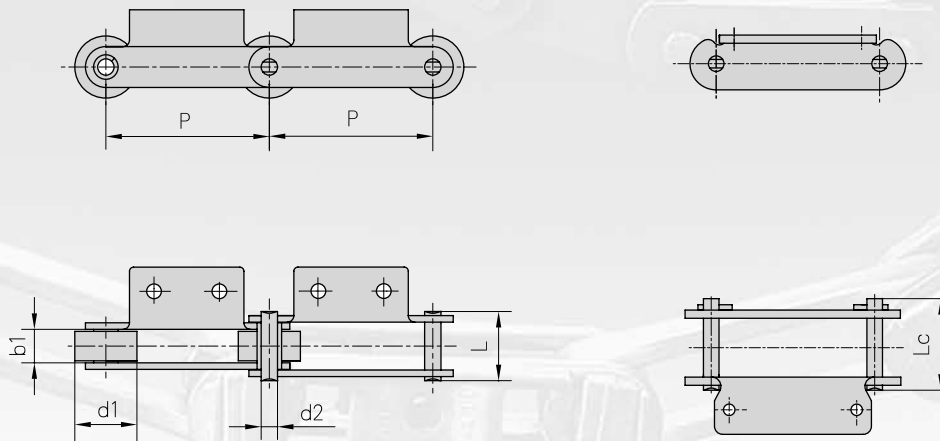

Flexon	Teilung	Rollen \varnothing	Lichte Weite	Bolzen \varnothing	Bolzenlänge		min. Bruchkraft	Durchschn. Bruchlast	Gewicht per meter
Chain No.	Pitch	Roller diameter	Width between innerplates	Pin diameter	Pin length		Ultimate tensile strength	Average tensile strength	Weight per meter
	P	d1 max	b1 min	d2 max	L max	Lc max	Q min	Q0	q
	mm	mm	mm	mm	mm	mm	kN/LB	kN	kg/m
P125F2	125,0	32,0	18,5	8,00	39,0		50,0/11364	55,0	2,66
P150F2	150,0	40,0	27,0	11,10	57,0	61,0	124,6/28318	137,0	5,40
P150F4	150,0	50,0	37,0	16,00	77,5	82,5	170,0/38636	187,0	10,90
P150F6	150,0	50,0	30,0	12,00	49,5		86,7/19704	95,0	7,27
RF10150RA2	150,0	50,8	30,0	14,50	69,0		113,0/25682	124,0	9,20
P152F	152,4	40,1	37,5	19,10	97,5		328,7/74704	378,0	15,88
P152F4	152,4	50,8	30,6	14,27	62,8	67,5	88,0/20000	100,0	9,24
P152F11	152,4	38,0	53,5	14,70	112,4		130,0/29545	143,0	12,6
*P160F1	160,0	36,0	55,0	20,00	108,0		50,0/11364	55,0	14,5
P160F3	160,0	48,0	25,0	14,85	62,5		120,0/27272	132,0	7,10
P160F5	160,0	60,0	33,0	14,27	64,0	72,0	150,0/34091	165,0	8,00
P160F8	160,0	40,0	20,0	11,00	50,0		55,0/12500	61,0	4,58
P185	185,0	50,8	30,6	14,27	62,8	67,5	70,0/15909	77,0	8,42
P200F6	200,0	50,0	37,0	16,00	77,5	82,5	170,0/38636	187,0	9,69
P200F7	200,0	40,0	27,0	11,10	57,0	61,0	124,6/28318	137,0	9,78
P200F8	200,0	65,0	37,0	16,00	86,5		170,0/38636	187,0	15,23

*Buchsenketten: In der Tabelle zeigt d1 den Außen \varnothing der Buchse

*Bushing chain: d1 in the table indicate the external diameter of the bushing



Förderketten mit Anbauteilen nach Werksnorm

Conveyor chains with attachments acc. to Industry standard

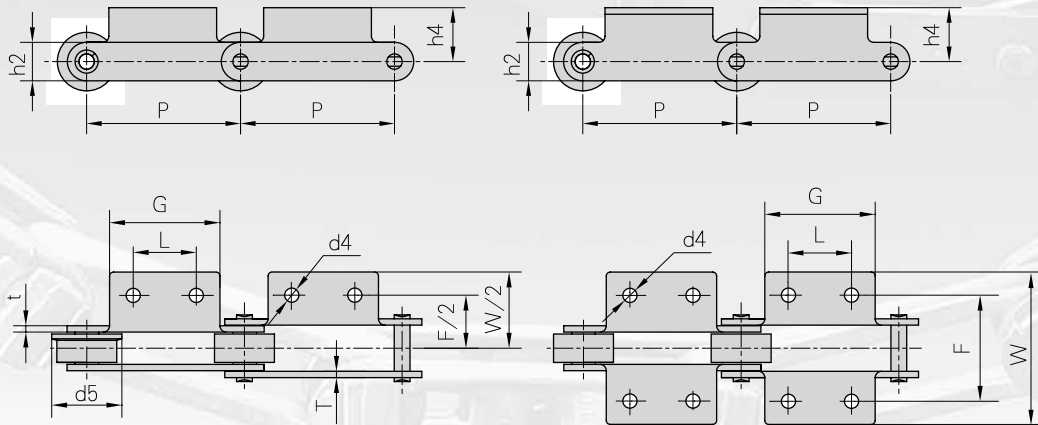

Flexon Chain No.	P	L	G	F	W	h4	h2	d4	t/T	d5
	mm	mm	mm	mm	mm	mm	mm	mm	mm	mm
P125F2	125,0	46,0	76,0	64,0	90,0	14,0	22,0	10,0	3,0	42,0
P150F2	150,0	60,0	85,0	92,0	117,3	22,5	32,0	10,0	6,0	
P150F4	150,0	60,0	85,0	120,0	150,0	33,0	43,0	14,0	8,0	
P150F6	150,0	50,0	75,0	86,6	126,6	17,5	35,0	9,0X26,0	4,0	59,0
RF10150RA2	150,0	60,0	90,0	100,0	130,0	28,0	38,1	12,0	6,3	
P152F	152,4	60,0	100,0	130,0	202,0	45,0	50,0	15,0	9,0	
P152F4	152,4	60,0	100,0	110,0	140,0	32,0	38,0	15,0	6,0	65,0
P152F11	152,4	44,6	74,8	133,7	168,0	24,0	39,0	10,8	9,6/11,4	
*P160F1	160,0	60,0	110,0	130,0	173,0	40,0	50,0	14,0	9,0	
P160F3	160,0	49,0	70,0	83,0	117,0	32,5	35,0	8,5	6,0	
P160F5	160,0	35,0	70,0	110,0	166,0	38,7	40,0	14,0	5,6	
P160F8	160,0	80,5	133,0	56,0	100,0	16,0	32,0	8,3X13,3	4,5	
P185	185,0	60,0	120,0	110,0	140,0	32,0	38,0	15,0	6,0	65,0
P200F6	200,0	81,5	120,0	120,0	150,0	33,0	43,0	14,0	8,0	
P200F7	200,0	81,5	120,0	92,0	122,0	22,0	32,0	10,0	6,0	
P200F8	200,0	80,0	120,0	200,0	238,0	38,0	43,0	15,0	8,0	80,0

*Buchsenketten: In der Tabelle zeigt d1 den AußenØ der Buchse
 *Bushing chain: d1 in the table indicate the external diameter of the bushing



Förderketten mit Anbauteilen nach Werksnorm

Conveyor chains with attachments acc. to Industry standard

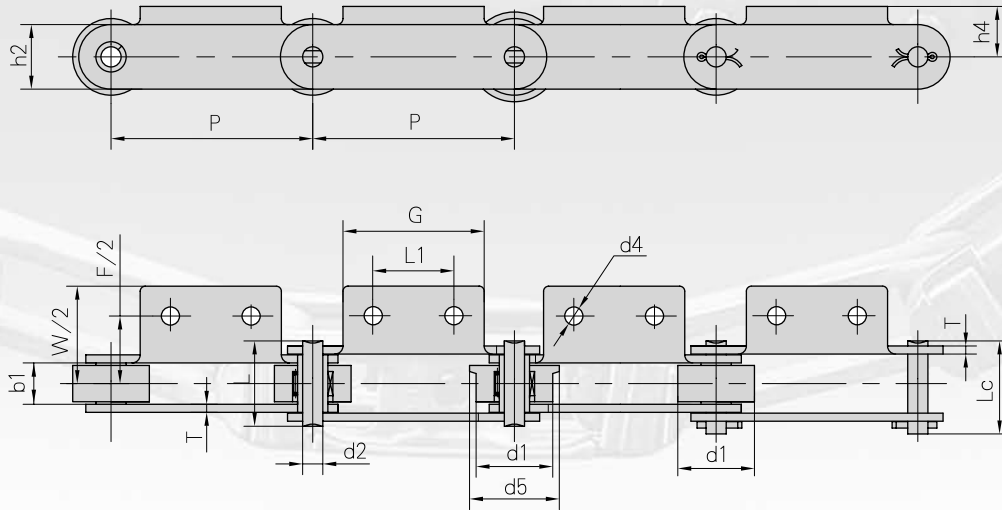

Flexon	Teilung	Rollen ø	Lichte Weite	Bolzen ø	Bolzen- länge		min. Bruchkraft	Durchschn. Bruchlast	Gewicht per meter
Chain No.	Pitch	Roller diameter	Width between inner plates	Pin diameter	Pin length		Ultimate tensile strength	Average tensile strength	Weight per meter
	P	d1 max	b1 min	d2 max	L max	Lc max	Q min	Q0	q
	mm	mm	mm	mm	mm	mm	kN/LB	kN	kg/m
M56F4-P-100	100,0	38,0	20,5	10,00	42,3	46,1	56,0/12727	62,0	4,30
M56F7-P-100	100,0	38,0	17,0	10,00	38,8	42,6	56,0/12727	62,0	4,84
M56F9-P-100	100,0	38,0	20,5	10,00	46,3	50,1	88,2/20045	97,0	5,60
P100	100,0	50,0	29,9	13,94	60,0		160,0/36364	176,0	9,27
P160	160,0	50,0	29,9	13,94	60,0		160,0/36364	176,0	7,23
P300	300,0	80,0	45,0	23,81	95,5	103,0	300,0/68181	320,0	24,32
P400F1	400,0	80,0	45,0	23,81	95,5	103,0	300,0/68181	320,0	22,67

Flexon Chain No.	L1	G	F	W	h4	h2	d4	T	d5
	mm	mm	mm	mm	mm	mm	mm	mm	mm
M56F4-P-100	40,0	70,0	68,5	98,50	25,0	25,0	9,0	4,0	44,5
M56F7-P-100	40,0	70,0	71,5	92,00	55,0	25,0	6,5	4,0	45,0
M56F9-P-100	40,0	70,0	67,5	96,58	25,0	32,0	9,0	5,0	44,5
P100	40,0	65,0	98,0	128,00	35,0	40,0	10,0	4,0	65,0
P160	85,0	115,0	94,0	124,00	35,0	40,0	10,0	4,0	65,0
P300	200,0	250,0	150,0	190,00	105,0	60,0	13,0	10,0	100,0
P400F1	300,0	350,0	150,0	190,00	105,0	60,0	15,0	10,0	100,0



Tragförderkette mit beidseitigen Führungsblöcken

Deep link conveyor chains with side guides

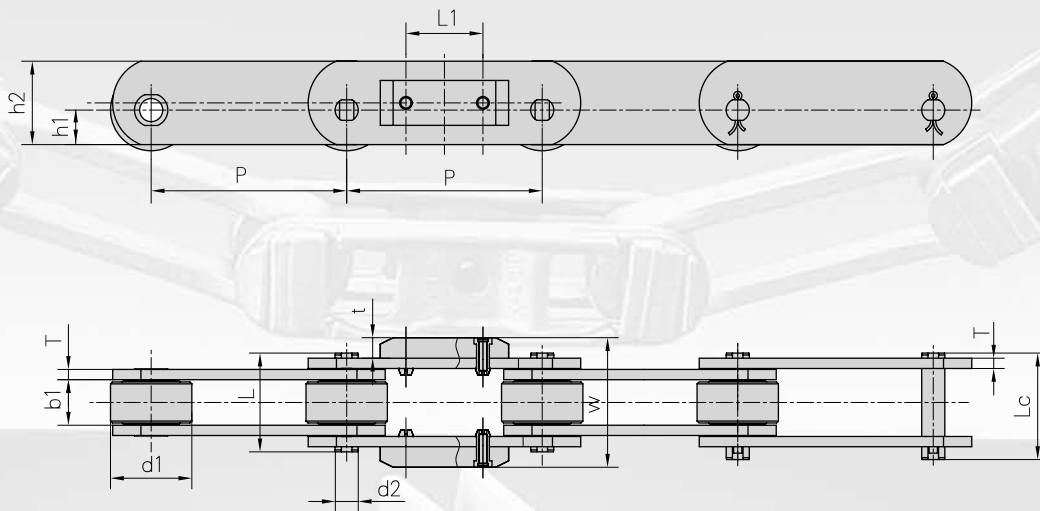

Flexon Chain No.	P	L1	W	t
	mm	mm	mm	mm
P152F13	152,4	60,0	101,0	16,0

Flexon Chain No.	Teilung	Rollen \varnothing	Lichte Weite	Bolzen \varnothing	Bolzenlänge		Laschenhöhe		Laschen- dicke	min. Bruchkraft
	Pitch	Roller diameter	Width between inner plates	Pin diameter	Pin length		Plate depth		Plate thickness	Ultimate tensile strength
	P	d1 max	b1 min	d2 max	L max	Lc max	h1 max	h2 max	T max	Q min
	mm	mm	mm	mm	mm	mm	mm	mm	mm	kN/LB
P152F13	152,4	63,4	35,0	18,0	77,0	83,0	26,9	65,0	8,0	160,0/36364



Tragförderketten mit Sonderlaschen

Deep link conveyor chains with special link plates

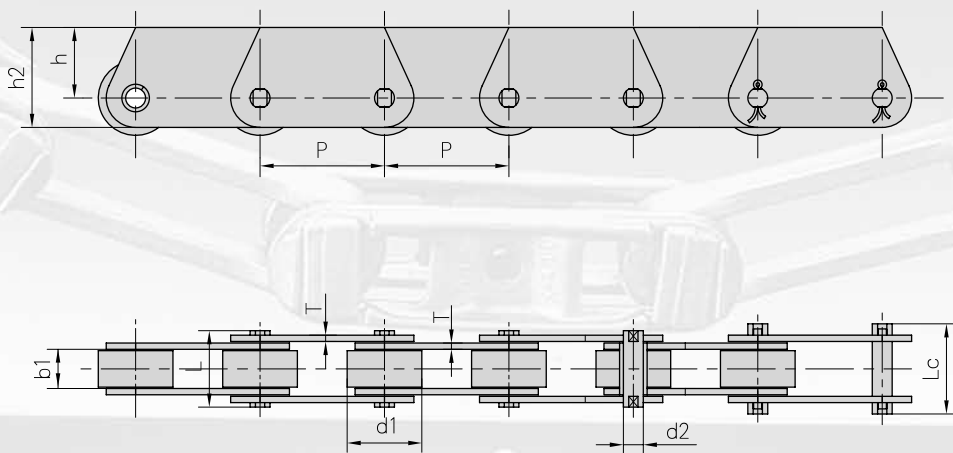

Flexon Chain No.	Teilung	Rollen Ø	Lichte Weite	Bolzen Ø	Bolzen- länge		Laschen- höhe		Laschen- dicke	min. Bruchkraft	Gewicht per meter
	Pitch	Roller diameter	Width between inner plates	Pin diameter	L	Lc	h	h2	T	Ultimate tensile strength	Weight per meter
	P	d1 max	b1 min	d2 max	L max	Lc max	h max	h2 max	T max	Q min	q
	mm	mm	mm	mm	mm	mm	mm	mm	mm	kN/LB	kg/m
P31,75F1	31,75	19,05	9,8	5,08	19,2	22,5	18,0	25,5	1,6	20,0/4545	1,48
P101.6F10	101,60	50,00	30,0	14,27	64,0	68,5	30,0	50,0	6,4	180,0/40909	11,56
P160F2	160,00	60,00	38,0	20,00	80,0		36,0	60,0	6,0	190,0/43181	12,57



Förderketten mit Anbauteilen

Conveyor chains with attachments

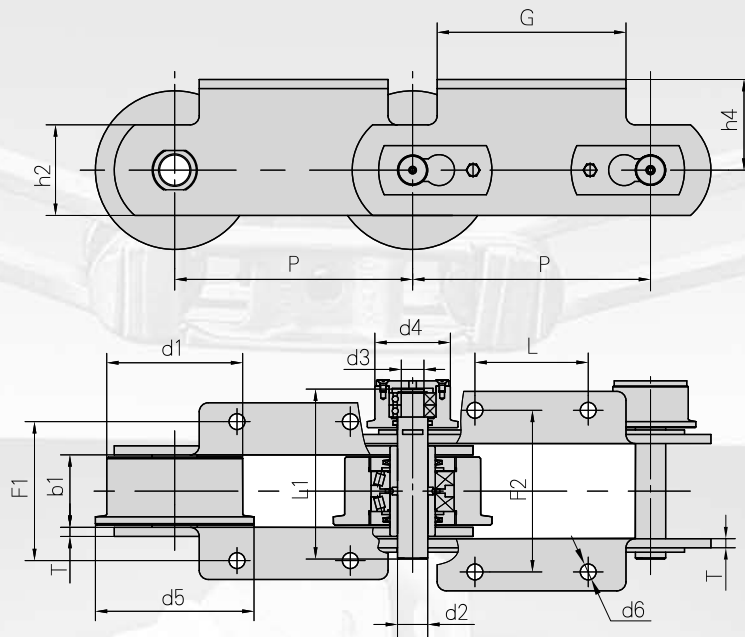

Flexon Chain No.	P	L	G	F1	F2	h4	h2	d6	T
	mm	mm	mm	mm	mm	mm	mm	mm	mm
P315	315	150,0	250,0	180,0	206,0	120,0	120,0	21,0	12,0

Flexon Chain No.	Teilung <i>Pitch</i>	Rollen \emptyset <i>Roller diameter</i>			Lichte Weite <i>Width between inner plates</i>	Bolzen \emptyset <i>Pin diameter</i>		Bolzenlänge <i>Pin length</i>	min. Bruchkraft <i>Ultimate tensile strength</i>
	P	d1 max	d4 max	d5 max	b1 min	d2 max	d3 max	L1 max	Q min
	mm	mm	mm	mm	mm	mm	mm	L1 max	kN/LB
P315	315	180,0	100,0	210,0	90,0	40,0	30,0	217,0	100,0/22727



Kardanketten für Kreisförderer

Cardan chains for Overhead and Floor conveyors

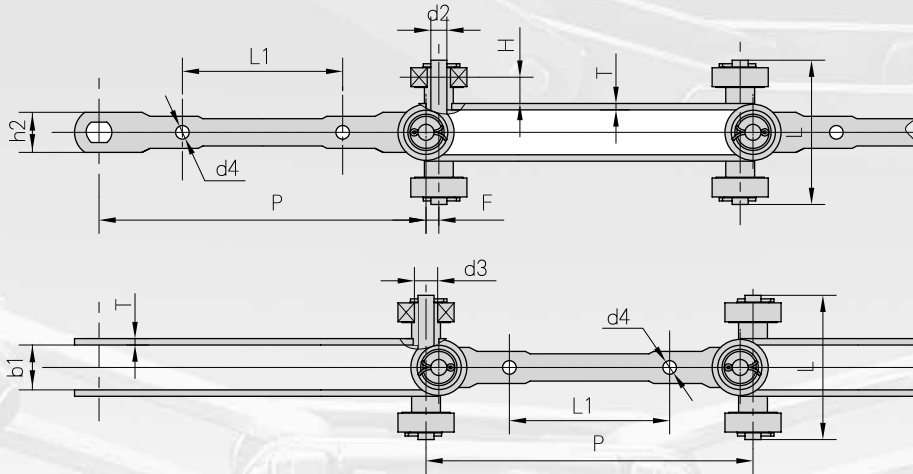

Flexon	Teilung	Buchsen ø	Lichte Weite	Bolzen- abmessungen		Laschen- abmessungen		Abmessungen Anbauteile				min. Bruchkraft
Chain No.	Pitch	Bush diameter	Width between inner plates	Pin dimension		Plate dimension		Attachment dimension				Ultimate tensile strength
	P	d3 max	b1 min	d2 max	L max	h2 max	T max	L1 max	d4 max	H	F	Q min
	mm	mm	mm	mm	mm	mm	mm	mm	mm	mm	mm	kN/LB
P210	204,0	14,5	27,5	10,0	90,0	25,0	4,0	100,0	8,5	16,0	8,0	50/11364

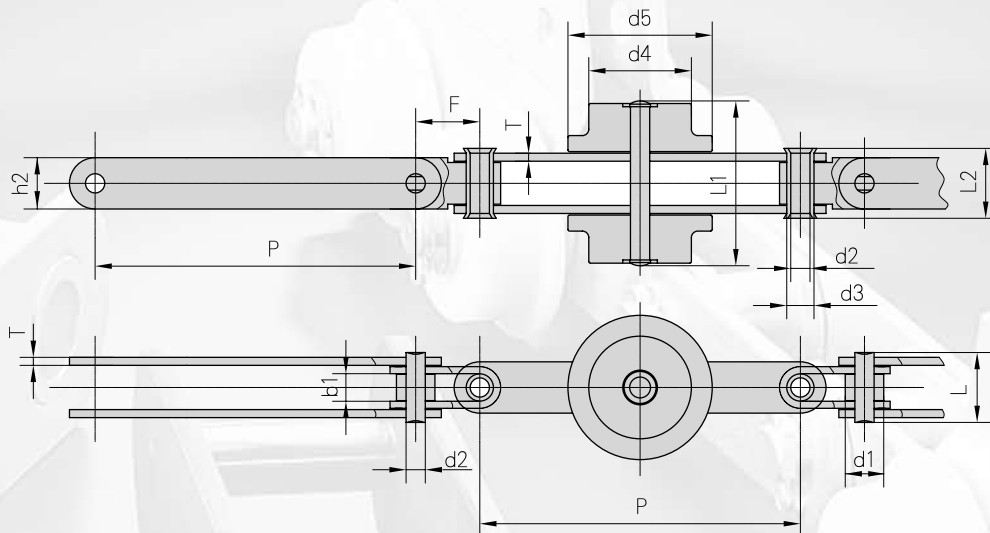

Flexon	Teilung	Rollen ø			Lichte Weite	Bolzen- abmessungen					Laschen- höhe	Laschen- dicke	Abmes- sungen Anbauteile	min. Bruchkraft
Chain No.	Pitch	Roller diameter			Width between inner plates	Pin dimension					Plate depth	Plate thickness	Attach- ment dimension	Ultimate tensile strength
	P	d1 max	d4 max	d5 max	b1 min	d2	d3	L max	L1 max	L2 max	h2 max	T max	F	Q min
	mm	mm	mm	mm	mm	mm	mm	mm	mm	mm	mm	mm	mm	kN/LB
P100F11	100,0	12,0	32,0	45,0	8,6	6,0	8,5	22,0	53,0	22,0	16,0	2,5	20,0	20/4545



Kratzer-Ketten nach DIN 8167 und DIN 8165 (M + FV Serie)

Scraper conveyor chains acc. to DIN 8167 and DIN 8165 (M + FV series)

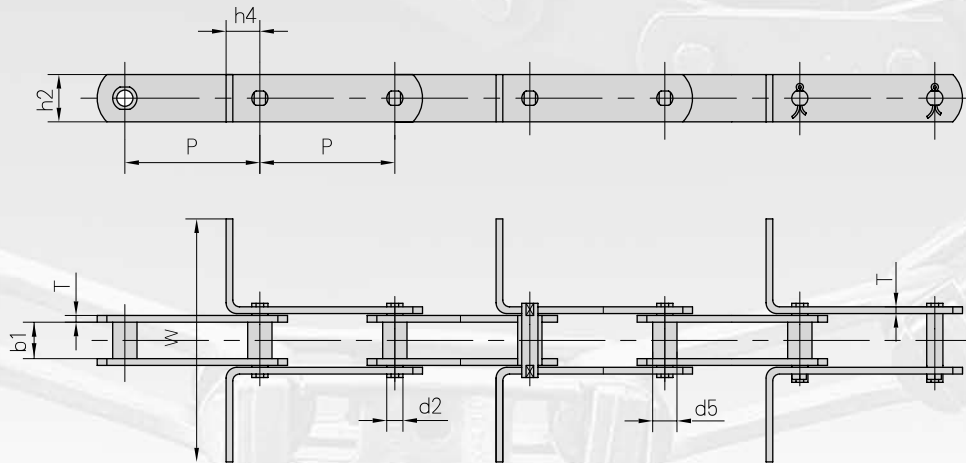

Flexon Chain No.	P			b1 min	d2 max	d5 max	h4	h2 max	T max	W	Q min
	mm	mm	mm								
MR56	100	125		24,0	10,0	15,0	20,0	30,0	4,0	•	56,0/12727
MR80	100	125	160	28,0	12,0	18,0	25,0	35,0	5,0	•	80,0/18182
MR112	100	125	160	32,0	15,0	21,0	35,0	40,0	6,0	•	112,0/25454
MR160	100	125	160	37,0	18,0	25,0	40,0	50,0	7,0	•	160,0/36364
MR224	125	160	200	43,0	21,0	30,0	44,0	60,0	8,0	•	224,0/50909
MR315	160	200	250	48,0	25,0	36,0	50,0	70,0	10,0	•	315,0/71591

Flexon Chain No.	p			b1 min	d2 max	d5 max	h4	h2 max	T max	W	Q min
	mm	mm	mm								
FVR40	80	100	125	18,0	10,0	15,0	20,0	25,0	3,0	•	42,0/9545
FVR63	100	125	160	22,0	12,0	18,0	25,0	30,0	4,0	•	64,0/14545
FVR90	100	125	160	25,0	14,0	20,0	30,0	35,0	5,0	•	100,0/22727
FVR112	100	125	160	30,0	16,0	22,0	35,0	40,0	6,0	•	120,0/27272
FVR140	125	160	200	35,0	18,0	26,0	38,0	45,0	6,0	•	145,0/32954
FVR180	125	160	200	45,0	20,0	30,0	44,0	50,0	8,0	•	190,0/43181
FVR250	160	200	250	55,0	26,0	36,0	50,0	60,0	8,0	•	275,0/62499

• W - Abmessungen auf Anfrage
 W - Dimensions are available upon request



Kratzer-Ketten nach Werksnorm

Scraper conveyor chains acc. to Industry standard

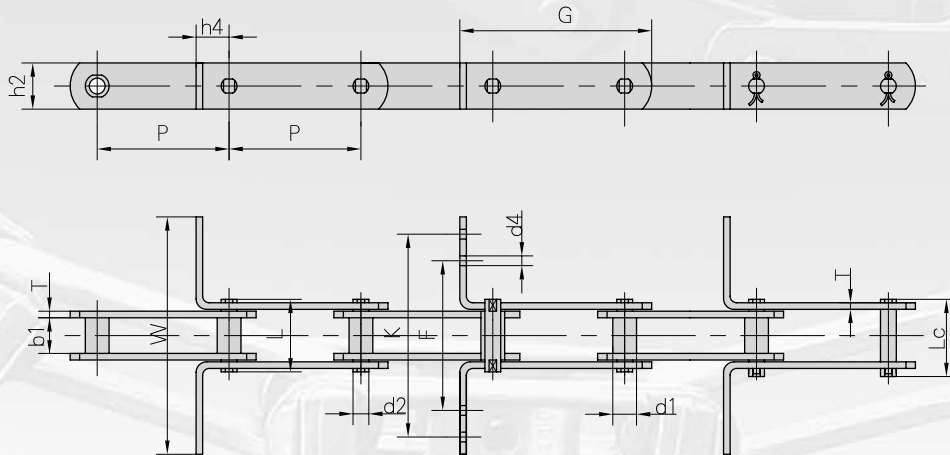

Flexon	Teilung	Buchsen ø	Lichte Weite	Bolzen ø	Bolzen- länge		min. Bruchkraft	Durchschn. Bruchlast	Gewicht per meter
Chain No.	Pitch	Bush diameter	Width between inner plates	Pin diameter	Pin length		Ultimate tensile strength	Average tensile strength	Weight per meter
	P	d1 max	b1 min	d2 max	L max	Lc max	Q min	Qo	q
	mm	mm	mm	mm	mm	mm	kN/LB	kN	kg/m
M80-P100F1	100,0	18,0	28,00	12,00	55,0	58,5	80,0/18162	88,0	5,19
M180-P-100	100,0	26,0	28,85	18,00	62,5		180,0/40909	198,0	10,25
M310-P-125	125,0	40,0*	52,00	20,00	103,4	109,4	303,8/69045	334,0	19,88
M310F1-P-125	125,0	40,0*	52,00	20,00	103,4	109,4	303,8/69045	334,0	24,88
P100F16	100,0	23,0	28,00	16,00	66,0		115,0/26136	127,0	6,60
P101.6	101,6	44,5	50,80	23,84	136,5		600,0/136362	660,0	34,96
P125F3	125,0	25,0	36,00	18,00	82,0		220,0/49999	242,0	11,17
P125F4	125,0	25,0	36,00	18,00	82,0		220,0/49999	242,0	9,83

* Außendurchmesser auf Anfrage
Dimension of roller diameter upon request

Flexon Chain No.	G	F	W	K	h4	h2	d4	T
	mm	mm	mm	mm	mm	mm	mm	mm
M80-P100F1	145,5		180,0		25,0	35,0		5,0
M180-P-100	163,0		185,0		35,0	50,0		6,0
M310-P-125	195,0		270,0		35,0	55,0		10,0
M310F1-P-125	195,0		560,0		35,0	55,0		10,0
P100F16	143,0	91,8	180,0	159,8	25,0	36,0	6,5	6,0
P101.6	198,6		206,5		62,0	60,0		14,5
P125F3	190,0	139,5	290,0	259,5	35,0	51,0	8,5	6,0
P125F4	190,0	119,5	220,0	191,5	35,0	51,0	8,5	6,0



Förderketten mit Sonderbauteilen

Conveyor chains with special attachments

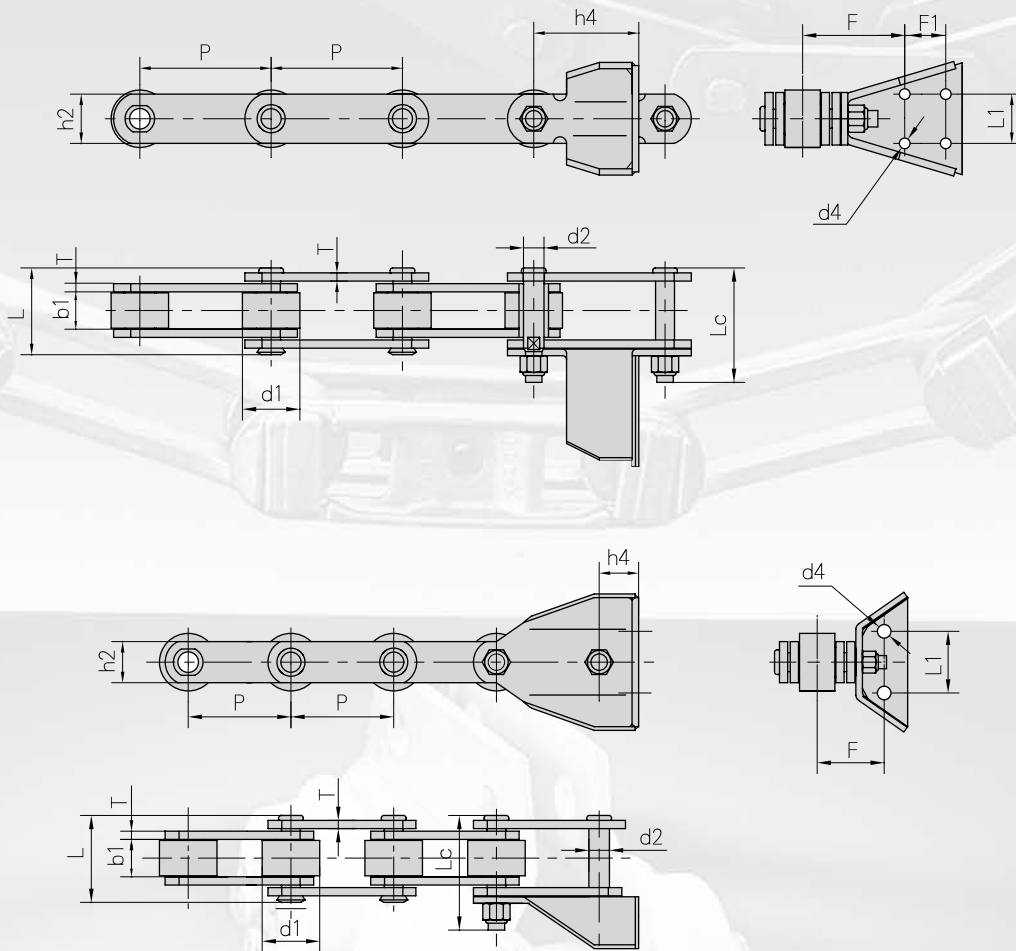

Flexon Chain No.	P	L1	F	d4	h4	F1
	mm	mm	mm	mm	mm	mm
P125F6	125,0	75,0	77,5	16,5	44,0	
P160F7	160,0	60,0	119,5	13,0	130,0	50,0

Flexon Chain No.	Teilung	Rollen \varnothing	Lichte Weite	Bolzen \varnothing		Bolzenlänge	Laschenhöhe	Laschendicke	min. Bruchkraft
	Pitch	Roller diameter	Width between inner plates	Pin diameter		Pin length	Plate depth	Plate thickness	Ultimate tensile strength
	P	d1 max	b1 min	d2 max	L max	Lc max	h2 max	T max	Q min
	mm	mm	mm	mm	mm	mm	mm	mm	kN/LB
P125F6	125,0	70,0	45,0	20,0	90,0	122,0	50,0	8,0	250/56818
P160F7	160,0	70,0	45,0	25,0	99,0	136,0	60,0	10,0	400/90908



Förderketten mit Sonderbauteilen

Conveyor chains with special attachments

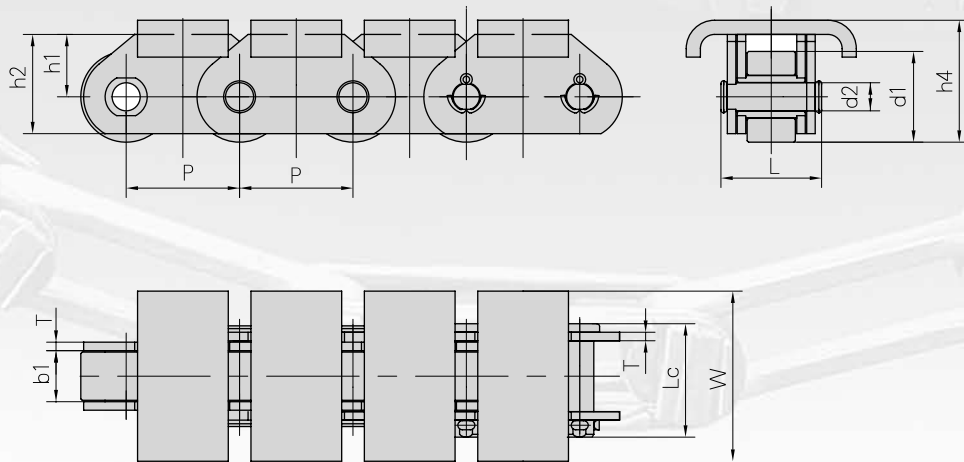

Flexon Chain No.	P	W	h4
	mm	mm	mm
P40F3	40,0	60,0	43,0

Flexon Chain No.	Teilung Pitch	Rollen ø Roller diameter	Lichte Weite Width between inner plates	Bolzen ø Pin diameter	Bolzenlänge Pin length		Laschenhöhe Plate depth		Laschenstärke Plate thickness	min. Bruchkraft Ultimate tensile strength	Gewicht per meter Weight per meter
	P	d1 max	b1 min	d2 max	L max	Lc max	h1 max	h2 max	T max	Q min	q
	mm	mm	mm	mm	mm	mm	mm	mm	mm	kN/LB	kg/m
P40F3	40,0	32,0	18,0	10,0	36,1	40,2	22,0	35,0	3,0	40,0/9091	7,27



Rollenketten für die Textilindustrie

Roller chains for textile machinery

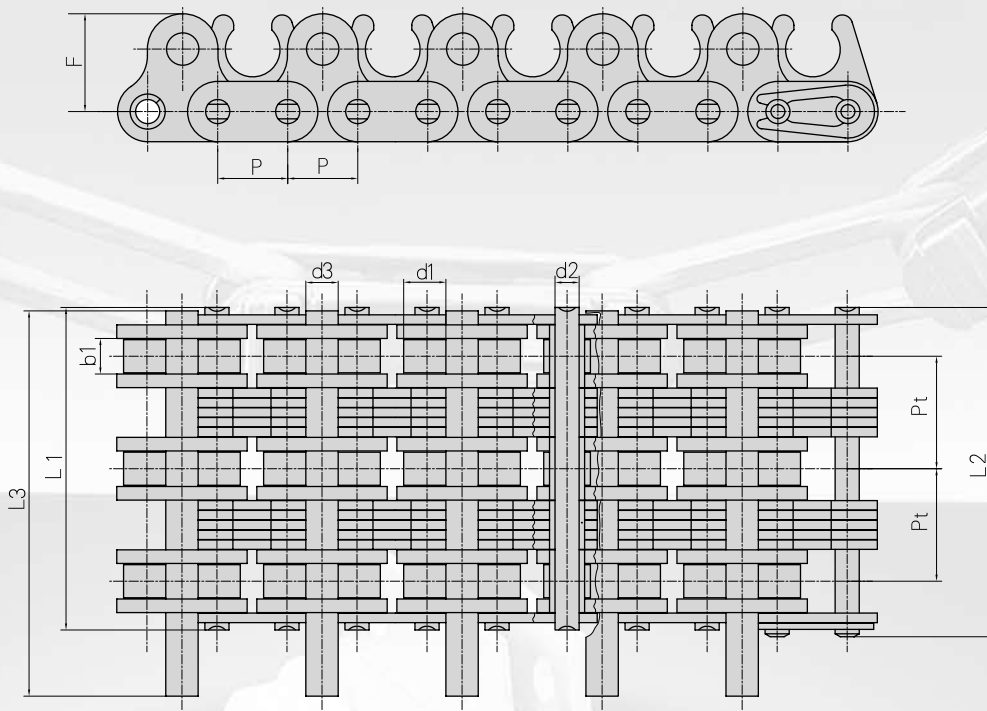

Flexon	Teilung	Rollen ø	Lichte Weite	Bolzen ø		Bolzen- länge			Ab- messungen Anbauteile Attachment dimension	Mitten- maß	min. Bruchkraft	Gewicht per meter
Chain No.	Pitch	Roller diameter	Width between inner plates	Pin diameter		Pin length				Transverse pitch	Ultimate tensile strength	Weight per meter
	P	d1 max	b1 min	d2 max	d3 max	L1 max	L2 max	L3 max	F	Pt	Q min	q
	mm	mm	mm	mm	mm	mm	mm	mm	mm	mm	kN/LB	kg/m
06BF20	9,525	6,35	4,6	3,28	4,45	43,75	44,85	52,4	13,0	15,0	24,9/5682	2,77



Spezial Ketten für den Folientransport und die Papierindustrie

Special chains for plastic film transport and for the paper industry

Rollenketten für Folientransport Roller chains for plastic film transport

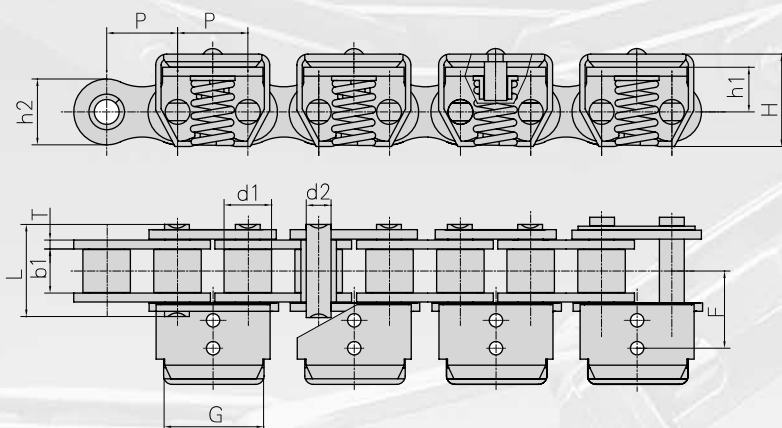

Flexon Chain No.	Teilung	Rollen \varnothing	Lichte Weite	Bolzenabmessungen		Laschen- und Anbauteileabmessungen					min. Bruchkraft	Gewicht per meter
	Pitch	Roller diameter	Width between inner plates	Pin dimension		Plate and attachment dimension					Ultimate tensile strength	Weight per meter
	P	d1 max	b1 min	d2 max	L max	h2 max	F	h1	H	T	Q min	q
	mm	mm	mm	mm	mm	mm	mm	mm	mm	mm	kN/LB	kg/m
08BSSF32	12,7	8,51	7,75	4,45	16,7	11,8	13,8	8,0	16,5	1,6	12,0/2727	1,14

Rollenketten für die Papierindustrie Conveyor chains for the paper industry

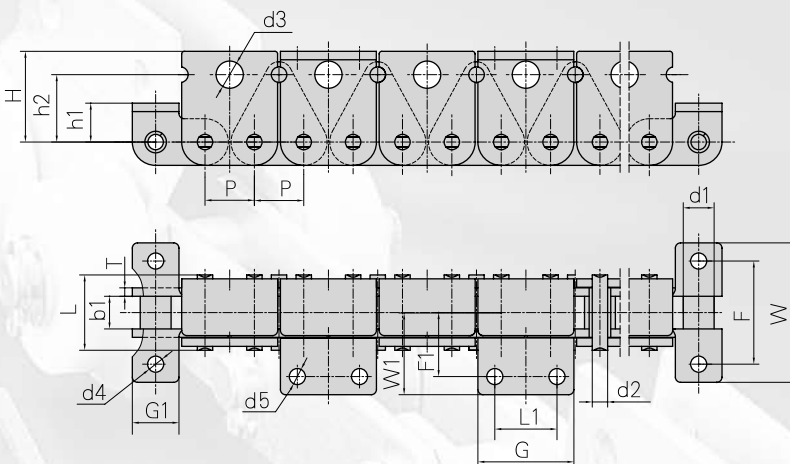

Flexon Chain No.	Teilung	Rollen \varnothing	Lichte Weite	Bolzen \varnothing	Bolzenlänge	min. Bruchkraft	Gewicht per meter
	Pitch	Roller diameter	Width between inner plates	Pin diameter	Pin length	Ultimate tensile strength	Weight per meter
	P	d1 max	b1 min	d2 mm	L max	Q min	q
	mm	mm	mm	mm	mm	kN/LB	kg/m
12AH-TB35	19,05	11,91	12,57	5,94	29,2	31,8/7227	4,35

Flexon Chain No.	H	h2	d3	F	W	G1	h1	d4	T	F1	W1	L1	G	d5
	mm	mm	mm	mm	mm	mm	mm	mm	mm	mm	mm	mm	mm	mm
12AH-TB35	35,0	26,0	10,5	40,0	54,0	18,0	15,0	6,2	3,25	24,8	31,8	24,0	37,0	6,2



Förderketten für die Papierindustrie

Conveyor chains for the paper industry

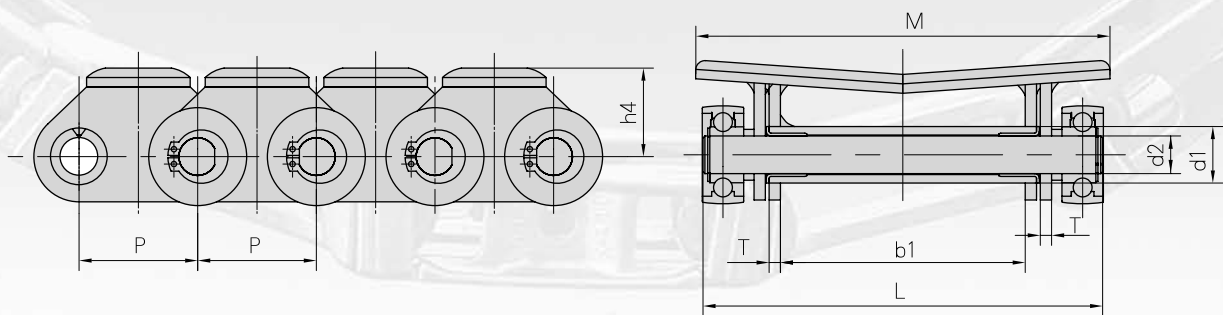

Flexon Chain No.	Teilung	Buchsen ∅	Lichte Weite	Bolzen ∅	Bolzen- länge	Laschen- dicke	Abmessungen Anbauteile		min. Bruchkraft	Durchschn. Bruchlast
	Pitch	Bush diameter	Width between inner plates	Pin diameter	Pin length	Plate thick- ness	Attachment dimension		Ultimate tensile strength	Average tensile strength
	P	d1 max	b1 min	d2 max	L max	T max	M	h4	Q min	Q0 min
	mm	mm	mm	mm	mm	mm	mm	mm	kN/LB	kN
63PF2	63,0	30,0	130,0	20,0	213,2	6,0	220,0	50,0	160,0/36364	176,0



Grabenziehketten

Dig chains

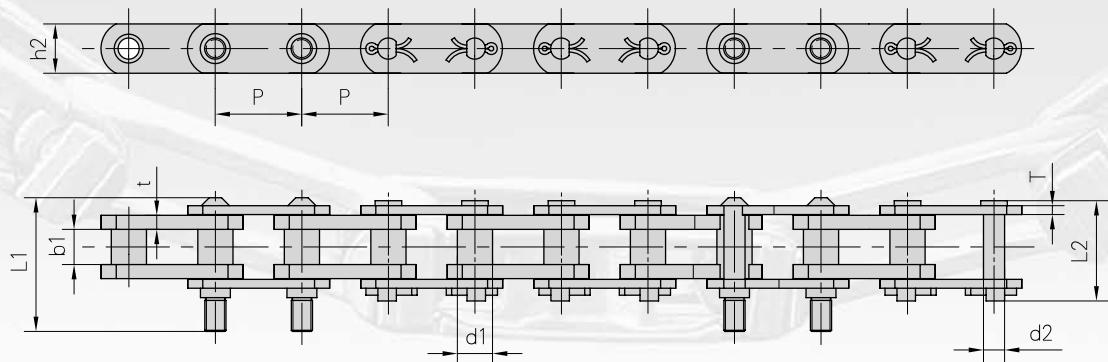

Flexon	Teilung	Buchsen \varnothing	Lichte Weite	Bolzen \varnothing	Bolzen- länge		Laschen- höhe	Laschen- dicke	min. Bruchkraft	Durchschn. Bruchlast	Gewicht per meter
Chain No.	Pitch	Bush diameter	Width between inner plates	Pin diameter	Pin length		Plate depth	Plate thick- ness	Ultimate tensile strength	Average tensile strength	Weight per meter
	P	d1 max	b1 min	d2 max	L1 max	L2 max	h2 max	t/T max	Q min	Qo min	q
	mm	mm	mm	mm	mm	mm	mm	mm	kN/LB	kN	kg/m
78PF1	78,1	31,75	31,75	19,05	122,0	90,5	44,5	12,7/8,0	140,0/31818	166,88	14,22



Rollenketten für Lackier- und Trocknungsanlagen

Roller chains for metal decorating systems

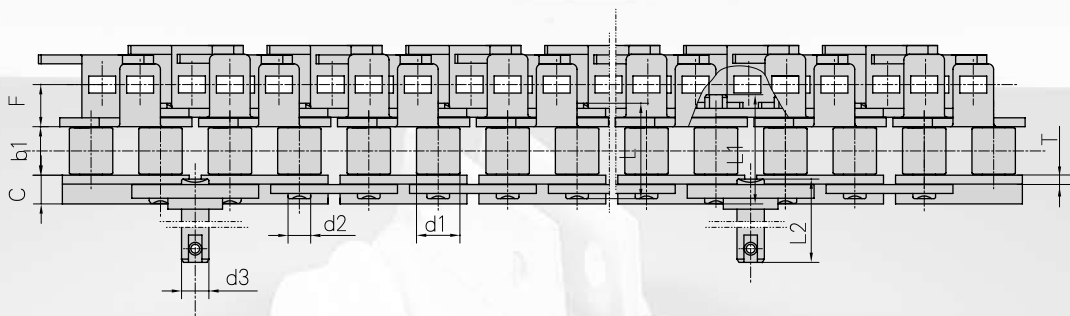
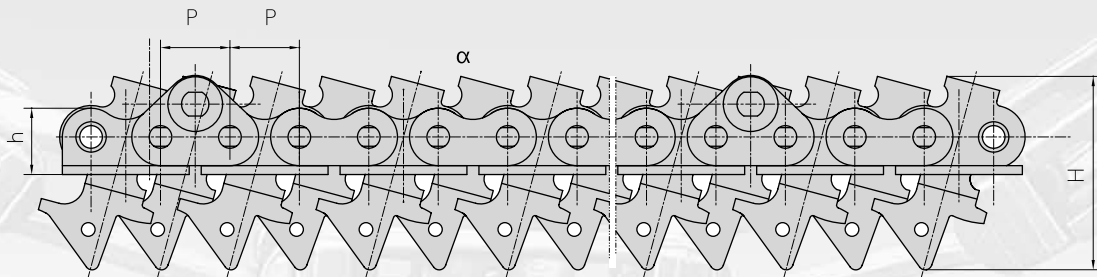

Flexon	Teilung	Rollen ø	Lichte Weite	Bolzen ø		Bolzen- länge			Laschenab- messungen		Abmessungen Anbauteile		min. Bruchkraft	
Chain No.	Pitch	Roller diameter	Width between inner plates	Pin diameter		Pin length			Plate dimension		Attachment dimension		Ultimate tensile strength	
	P	d1 max	b1 min	d2 max	d3 max	L max	L1 max	L2 max	h	T	H	F	C	Q min
	mm	mm	mm	mm	mm	mm	mm	mm	mm	mm	mm	mm	mm	kN/LB
16BF10	25,4	15,88	19,0	8,28	10,0	36,1	41,0	43,1	23,9	3,1	70,5	15,5	10,15	40,0/9090
16BF27	25,4	15,88	19,0	8,28	10,0	36,1	41,0	43,1	23,9	3,1	85,0	17,0	10,15	40,0/9090



Rollenketten für Lackier- und Trocknungsanlagen

Roller chains for metal decorating systems

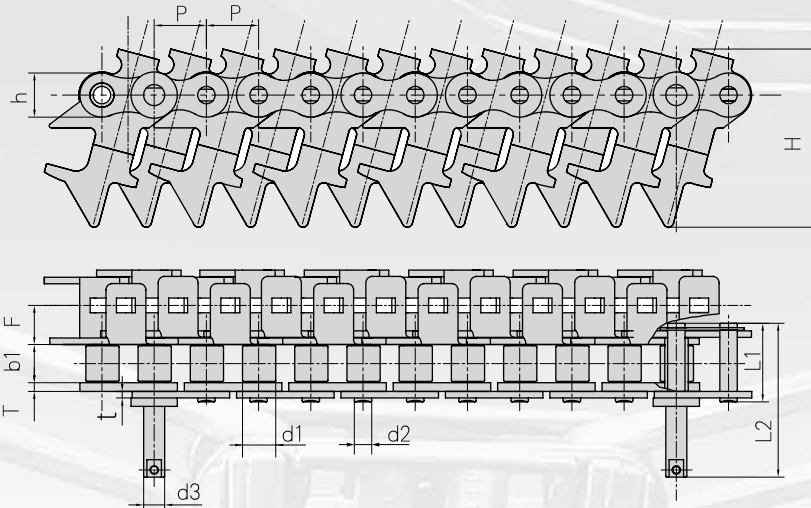

Flexon	Teilung	Rollen \varnothing	Lichte Weite	Bolzen \varnothing		Bolzenlänge		Laschenabmessungen			Abmessungen Anbauteile		min. Bruchkraft
Chain No.	Pitch	Roller diameter	Width between inner plates	Pin diameter		Pin length		Plate dimension			Attachment dimension		Ultimate tensile strength
	P	d1 max	b1 min	d2 max	d3 max	L1 max	L2 max	h	T	t	H	F	Q min
	mm	mm	mm	mm	mm	mm	mm	mm	mm	mm	mm	mm	kN/LB
16BF12	25,4	15,88	18,0	8,28	10,0	37,4	73,2	21,0	4,15	3,1	85,0	18,5	40,0/9090

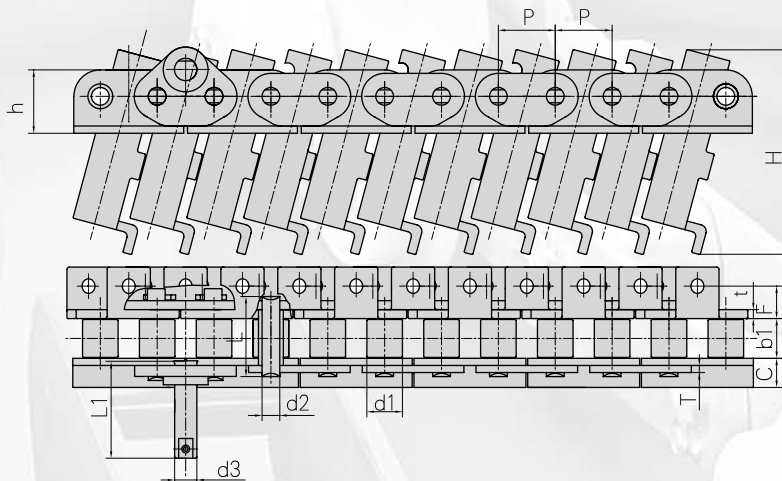

Flexon	Teilung	Rollen \varnothing	Lichte Weite	Bolzen \varnothing		Bolzenlänge		Laschenabmessungen			Abmessungen Anbauteile			min. Bruchkraft
Chain No.	Pitch	Roller diameter	Width between inner plates	Pin diameter		Pin length		Plate dimension			Attachment dimension			Ultimate tensile strength
	P	d1 max	b1 min	d2 max	d3 max	L	L1	h	T	t	H	F	C	Q
	mm	mm	mm	mm	mm	mm	mm	mm	mm	mm	mm	mm	mm	kN/LB
16AF18	25,4	15,88	17,0	7,92	10,0	36,2	48,6	28,3	3,25	4,0	92,0	14,7	13,0	40,0/9090



Rollenketten für Lackier- und Trocknungsanlagen

Roller chains for metal decorating systems

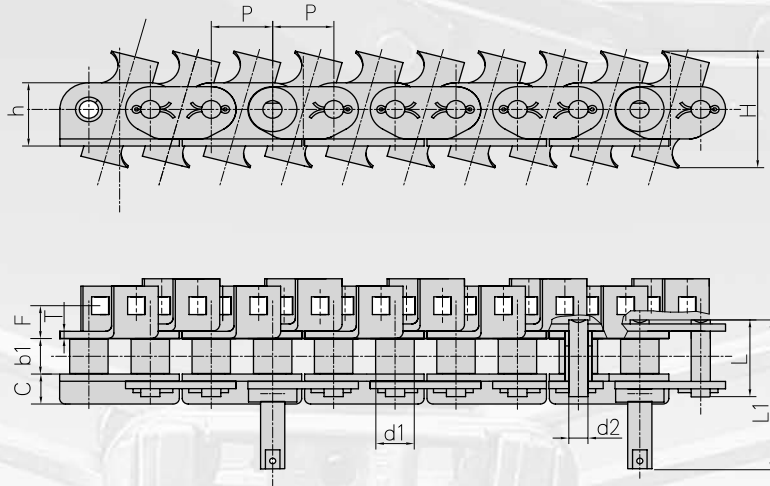

Flexon	Teilung	Rollen ø	Lichte Weite	Bolzen ø	Bolzen- länge		Laschen- abmessungen		Abmessungen Anbauteile			min. Bruchkraft
Chain No.	Pitch	Roller diameter	Width between inner plates	Pin diameter	Pin length		Plate dimension		Attachment dimension			Ultimate tensile strength
	P	d1 max	b1 min	d2 max	L	L1	h	T	H	F	C	Q min
	mm	mm	mm	mm	mm	mm	mm	mm	mm	mm	mm	kN/LB
16AF7	25,4	15,88	15,75	7,92	36,5	67,9	28,3	3,25	59,1	13,5	13,0	40,0/9090

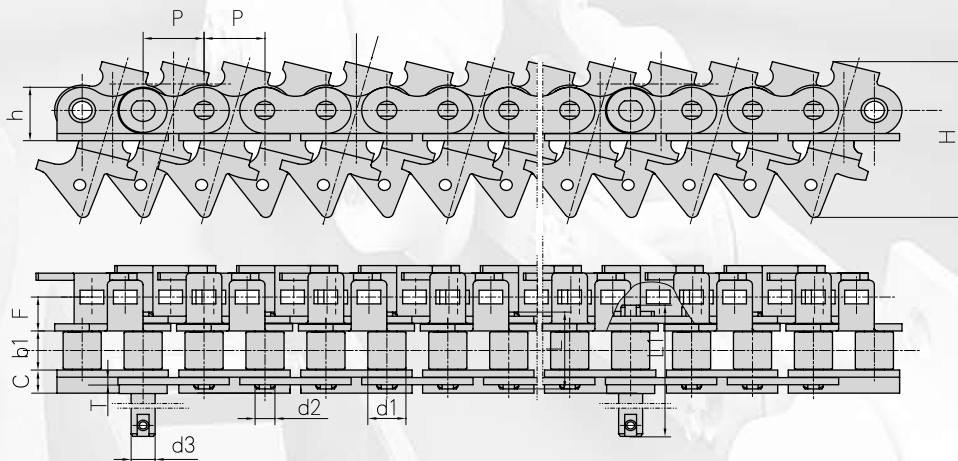

Flexon	Teilung	Rollen ø	Lichte Weite	Bolzen m		Bolzen- länge		Laschen- abmessungen		Abmessungen Anbauteile			min. Bruchkraft
Chain No.	Pitch	Roller diameter	Width between inner plates	Pin diameter		Pin length		Plate dimension		Attachment dimension			Ultimate tensile strength
	P	d1 max	b1 min	d2 max	d3 max	L	L1	h	T	H	F	C	Q min
	mm	mm	mm	mm	mm	mm	mm	mm	mm	mm	mm	mm	kN
16AF27	25,4	15,88	15,75	7,92	10,0	32,7	75,2	28,3	3,25	71,0	14,6	13,0	40,0



Plattenbandketten

Flat top conveyor chains

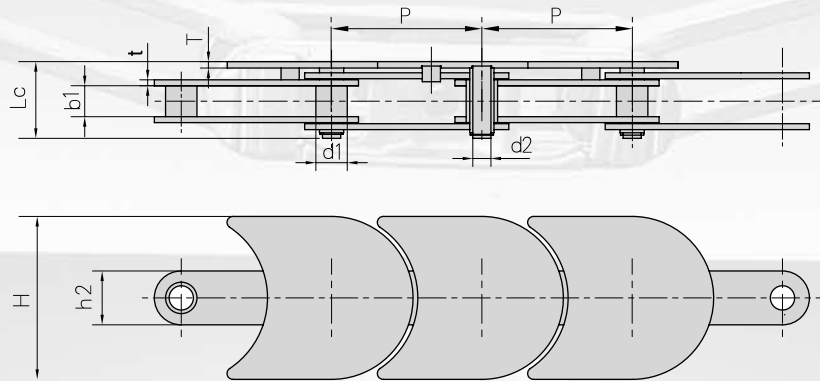

Flexon Chain No.	Teilung Pitch	Rollen Ø Roller diameter	Lichte Weite Width between innerplates	Bolzen- abmessungen		Laschen- abmessungen		Abmessungen Anbauteile		min. Bruchkraft Ultimate tensile strength	Gewicht per meter Weight per meter
				Pin dimension		Plate dimension		Attachment dimension			
				d1 max	b1 min	d2 max	Lc max	h2 max	t		
		mm	mm	mm	mm	mm	mm	mm	mm	kN/LB	kg/m
HMK 38-50	38,1	12,07	11,68	4,45	27,3	15,0	1,6	50,0	3,0	25,0/-	1,94
HMK 76-82	76,2	15,92	15,7	9,2	37,5	27,3	3,0	82,6	3,0	45,0/10227	2,76
HMK 76-114	76,2	15,92	15,7	9,2	37,5	27,3	3,0	114	3,0	45,0/10227	3,5



Förderketten aus Kunststoff Serie CC 600, CC 600 TAB, CC 600 F
und aus Temperguss Serie C 600, C 600 TAB
*Plastic conveyor chains series CC 600, CC 600 TAB, CC 600 F
and from Cast iron series C 600, C 600 TAB*

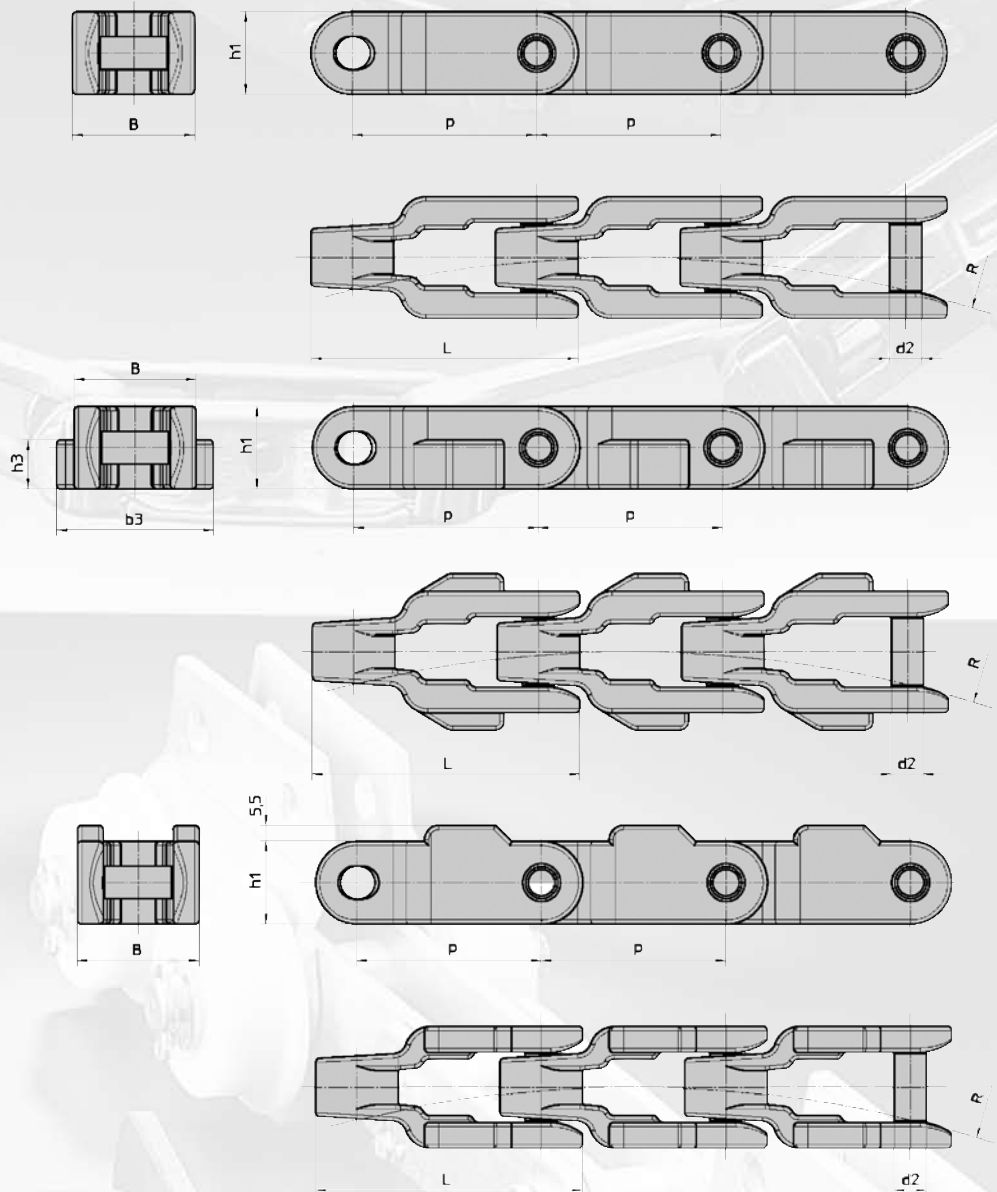

Flexon Chain No.	Teilung	Laschen- länge Plate length	Bolzen ø Pin diameter	Laschen- höhe Plate Width	Laschen- breite Link Width	Breite über TAB Width over Tab	Höhe TAB Height Tab	Seitenbogen- radius Side bow radius	Durchschn. Bruchlast Average tensile strength	Gewicht pro Meter Weight per meter
	P	L	d2 max	h1	B	b3	h3	R	Qo	q
	mm	mm	mm	mm	mm	mm	mm	mm	kN	kg/m
CC 600	63,5	92	11	28,5	42	-	-	530	14,000	1,39
CC 600 TAB	63,5	92	11	28,5	42	54	17	530	14,000	1,49
CC 600 F	63,5	92	11	28,5	42	-	-	530	14,000	1,45
C 600 *	63,5	92	11	28,5	42	-	-	760	55,000	5,22
C 600 TAB *	63,5	92	11	28,5	42	54	14,2	760	55,000	5,70

* Temperguss
* cast iron



Förderketten aus Kunststoff Serie CC 600 P, CC 600 TAB P, CC 631 TAB

Plastic conveyor chains series CC 600 P, CC 600 TAB P, CC 631 TAB

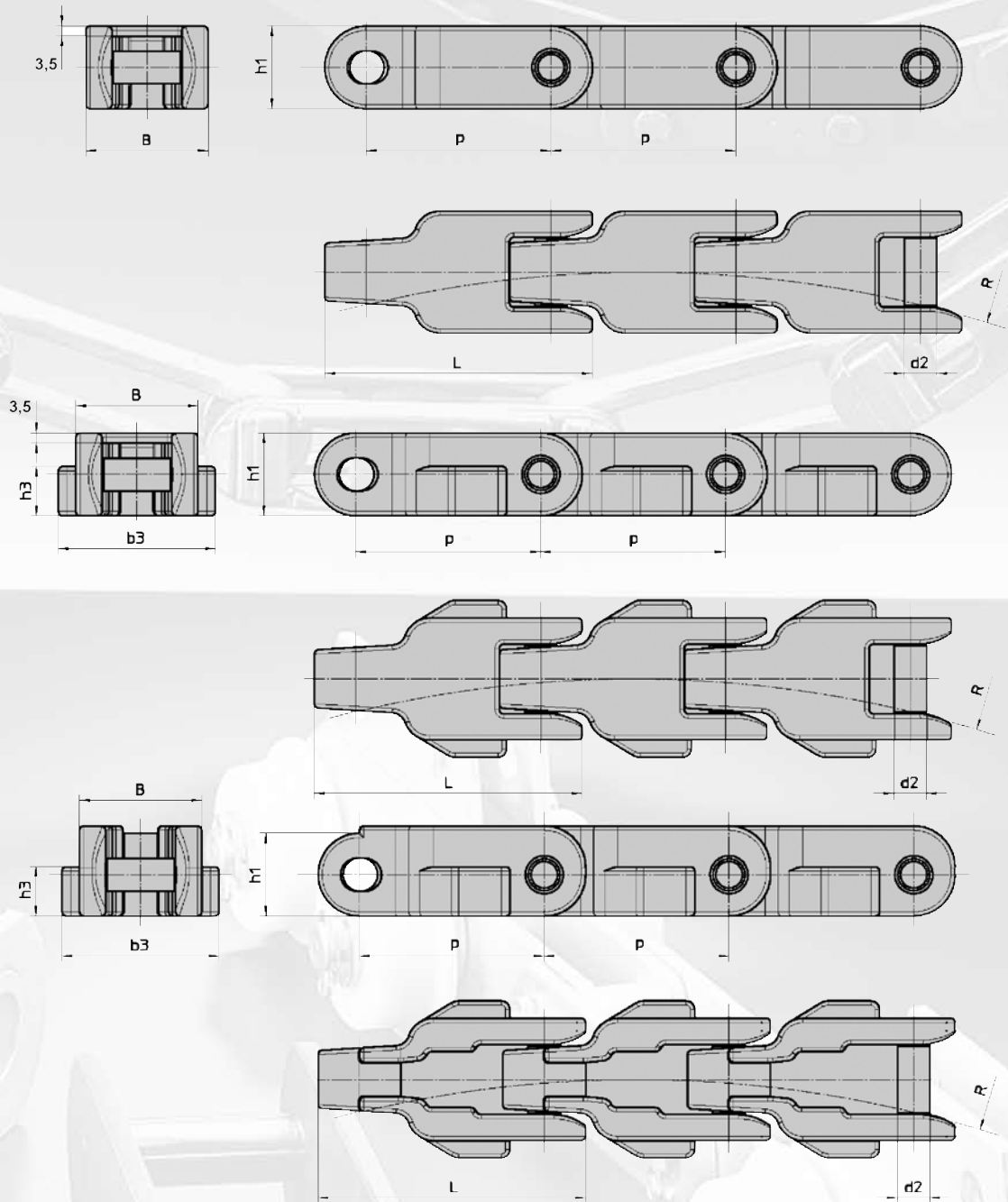

Flexon Chain No.	Teilung Pitch	Laschen- länge Plate length	Bolzen Ø Pin diameter	Laschen- höhe Plate Width	Laschen- breite Link Width	Breite über TAB Width over Tab	Höhe TAB Height Tab	Seitenbogen- radius Side bow radius	Durchschn. Bruchlast Average tensile strength	Gewicht per meter Weight per meter
	P	L	d2 max	h1	B	b3	h3	R	Qo	q
	mm	mm	mm	mm	mm	mm	mm	mm	kN	kg/m
CC 600 P	63,5	90	11	28,5	42,5	-	-	530	14,000	1,42
CC 600 TAB P	63,5	90	11	28,5	42,5	52	15	530	14,000	1,55
CC 631 TAB	63,5	90	11	28,5	42,0	54	17	530	14,000	1,45



Förderketten aus Kunststoff Serie CC 1400, CC 1400 TAB

Plastic conveyor chains series CC 1400, CC 1400 TAB

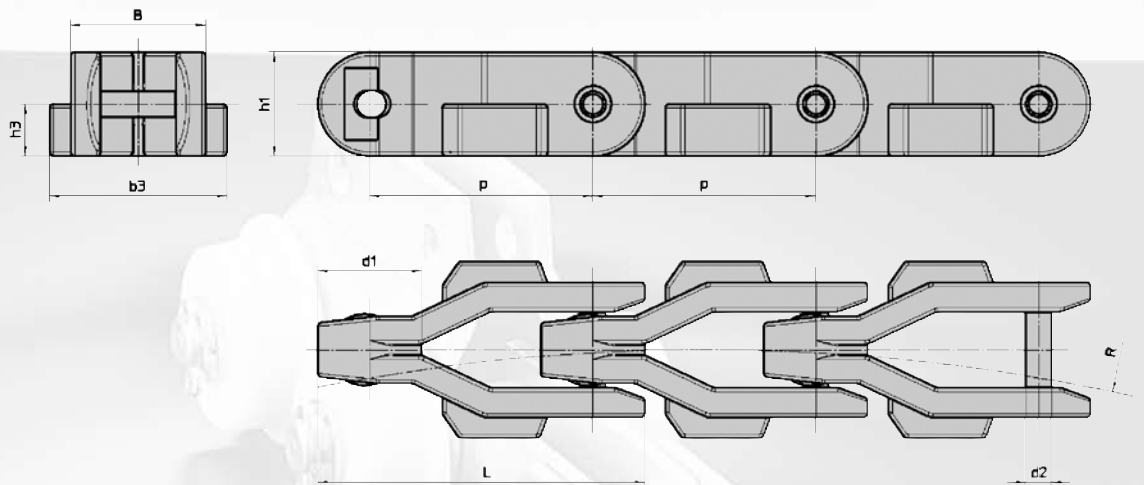
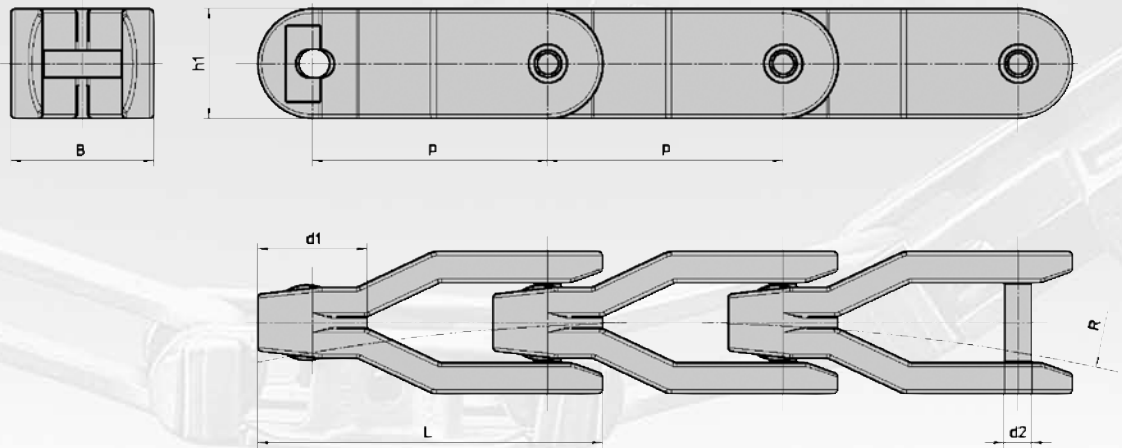

Flexon Chain No.	Teilung	Bolzen- abmessungen		Laschen- abmessungen			Breite über TAB	Höhe TAB	Seitenbogen- radius	min. Bruchkraft	Gewicht per meter
	Pitch	Pin dimension		Plate dimension			Width over TAB	TAB height	Side bow radius	Ultimate tensile strength	Weight per meter
	P	d2 max	L	h1 max	B max	d1	b3	h3	R min	Q min	q
	mm	mm	mm	mm	mm	mm	mm	mm	mm	kN/LB	kg/m
CC1400	82,5	9,5	48,0	38,5	50,0	38,0	-	-	660	18,0/ -	3,24
CC1400TAB	82,5	9,5	48,0	38,5	50,0	38,0	65,5	19,5	660	18,0/ -	3,44



Laschenketten, Ziehbankketten „Gallketten“

Multiple plates bearing pin chains „Gall chains“

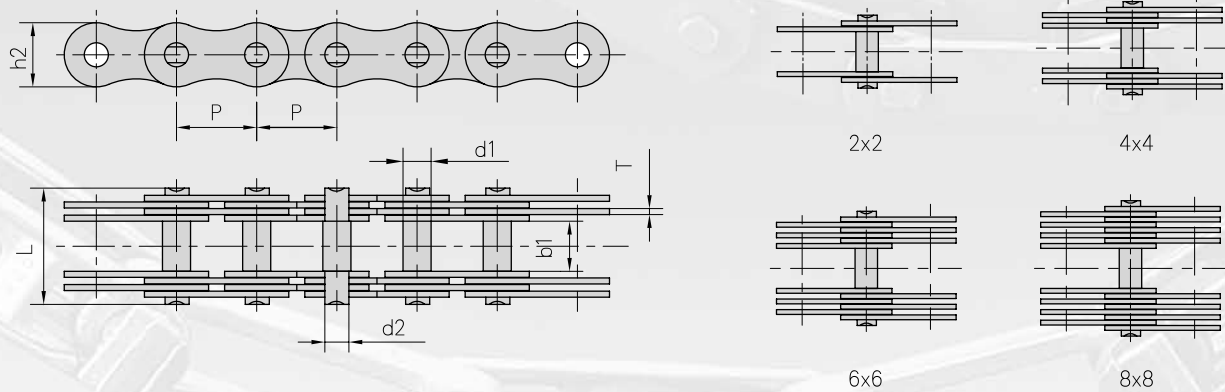

Flexon Chain No.	Teilung	Lichte Weite	Laschen- kombination	Bolzen ø		Bolzen- länge	Laschen- höhe	Laschen- dicke	min. Bruchkraft	Gewicht per meter
	Pitch	Width between inner plates	Plate Lacing	Pin diameter		Pin length	Plate depth	Plate thickness	Ultimate tensile strength	Weight per meter
	P	b1 min		d1 max	d2 max	L max	h2 max	T max	Q min	q
	mm	mm		mm	mm	mm	mm	mm	kN/LB	kg/m
MP15	15	12	2 X 2	5	4	25	12	2,03	5,0/1125	0,7
MP20	20	15	2 X 2	8	6	28	15	2,03	12,5/2818	1,1
MP25	25	18	2 X 2	10	8	36	18	3	25,0/5624	1,8
MP30	30	20	4 X 4	11	9	51	20	3	40,0/8999	3,4
MP35	35	22	4 X 4	12	10	53	26	3	60,0/13498	4,5
MP40	40	25	4 X 4	14	12	58	32	3	80,0/17998	5,0
MP45	45	30	4 X 4	17	14	63	35	3	100,0/22497	7,0
MP50	50	35	4 X 4	22	18	90	40	4,5	150,0/33746	11,3
MP55	55	40	4 X 4	24	21	108	42	6,0	200,0/44994	14,5
MP60	60	45	4 X 4	26	23	114	46	6,0	250,0/56243	17,1
MP70	70	50	6 X 6	32	28	148	55	6,0	375,0/84364	34,0
MP80	80	60	6 X 6	36	32	159	60	6,0	500,0/112486	39,0
MP90	90	70	6 X 6	40	36	184	70	7,0	750,0/168728	53,0
MP100	100	80	8 X 8	45	40	224	80	7,0	1000,0/224972	77,0
MP110	110	90	8 X 8	50	45	236	90	7,0	1250,0/281215	90,0
MP120	120	100	8 X 8	55	50	262	100	8,0	1500,0/337458	112,0



Buchsenketten nach amerik. Norm

Hoisting rollerless chains acc. to American standard

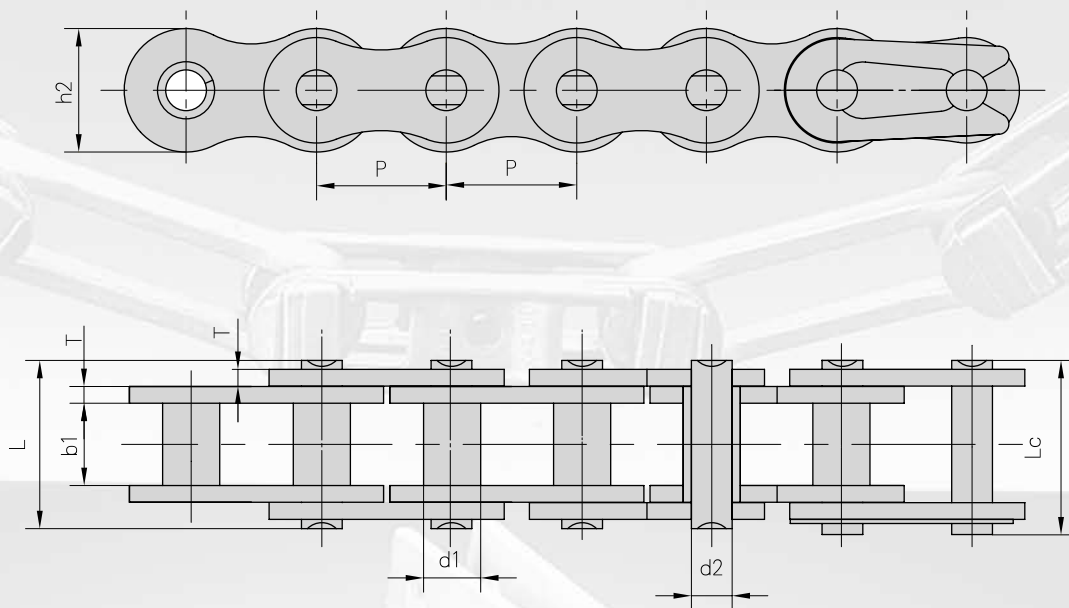

Flexon	Teilung	Buchsen ø	Lichte Weite	Bolzen ø	Bolzen länge		Höhe Innenlasche	Laschen- dicke	min. Bruchkraft	Durchschn. Bruchlast	Gewicht per meter
Chain No.	Pitch	Bush diameter	Width between inner plates	Pin diameter	Pin length		Inner plate depth	Plate thickness	Ultimate tensile strength	Average tensile strength	Weight per meter
	P	d1 max	b1 min	d2 max	L max	Lc max	h2 max	T max	Q min	Q0	q
	mm	mm	mm	mm	mm	mm	mm	mm	kN/LB	kN	kg/m
45-1	12,700	5,63	7,85	3,96	16,6	17,8	12,00	1,50	14,10/3205	17,5	0,54
55-1	15,875	7,03	9,40	5,08	20,7	22,2	15,09	2,03	22,20/5045	29,4	0,83
65-1	19,050	8,33	12,57	5,94	25,9	27,7	18,00	2,42	31,80/7227	41,5	1,22
85-1	25,400	11,10	15,75	7,92	32,7	35,0	24,00	3,25	56,70/12886	69,4	2,16
105-1	31,750	13,60	18,90	9,53	40,4	44,7	30,00	4,00	88,50/20114	109,2	3,31
125-1	38,100	15,60	25,22	11,10	50,3	54,3	35,70	4,80	127,00/28864	156,3	4,97
145-1	44,450	18,00	25,22	12,70	54,4	59,0	41,00	5,60	172,40/39182	212,0	6,50
165-1	50,800	20,00	31,55	14,27	64,8	69,6	47,80	6,40	226,80/51545	278,9	8,70



Förderketten für Spezialanwendung
Conveyor chains for special application

Förderketten für
Spezialanwendung





Förderketten für die Holzindustrie

Conveyor chains and attachments for the Timber Industry

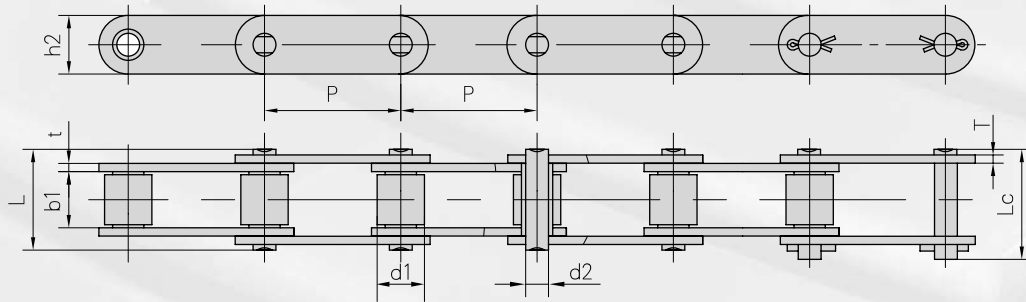

Flexon	Teilung	Rollen Ø	Lichte Weite	Bolzen Ø	Bolzenlänge		Höhe Innenlasche	Laschen- dicke	min. Bruchkraft	Durchschn. Bruchlast	Gewicht per meter
Chain No.	Pitch	Roller diameter	Width between inner plates	Pin diameter	Pin length		Inner plate depth	Plate thickness	Ultimate tensile strength	Average tensile strength	Weight per meter
	P	d1 max	b1 min	d2 max	L max	Lc max	h2 max	t/T max	Q min	Q0	q
	mm	mm	mm	mm	mm	mm	mm	mm	kN/LB	kN	kg/m
81X	66,27	23,00	27,00	11,10	49,0	53,5	28,50	4,00	106,7/24250	128,9	3,78
81 XH	66,27	23,00	27,78	11,10	60,7	65,1	31,35	7,94/5,55	151,9/34523	175,7	5,88
81XHH	66,27	23,00	27,78	11,10	65,6	70,0	31,35	7,94	191,1/43432	212,6	6,70
81XHS	66,27	23,00	27,00	11,10	63,6	68,0	31,80	7,60	152,0/34545	177,2	6,55
500R	50,00	25,40	25,40	14,63	52,0	56,4	40,00	5,00	100,0/22727	114,5	7,13
441.100R	100,00	25,40	25,40	14,63	52,0	56,4	40,00	5,00	100,0/22727	114,5	5,15

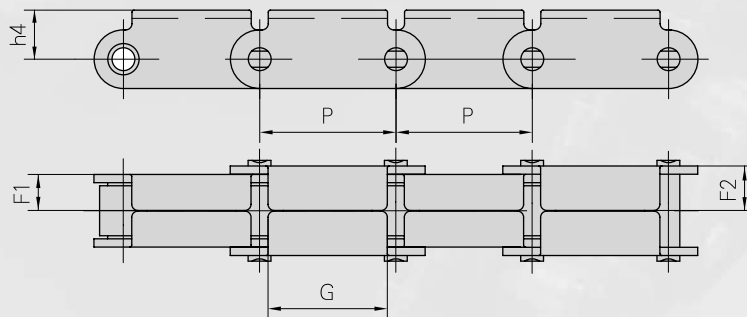

Flexon Chain No.	P	F1	F2	G	h4
	mm	mm	mm	mm	mm
81XF1(RT)	66,27	17,5	21,8	58,0	23,85



Förderketten für die Holzindustrie

Conveyor chains and attachments for the Timber Industry

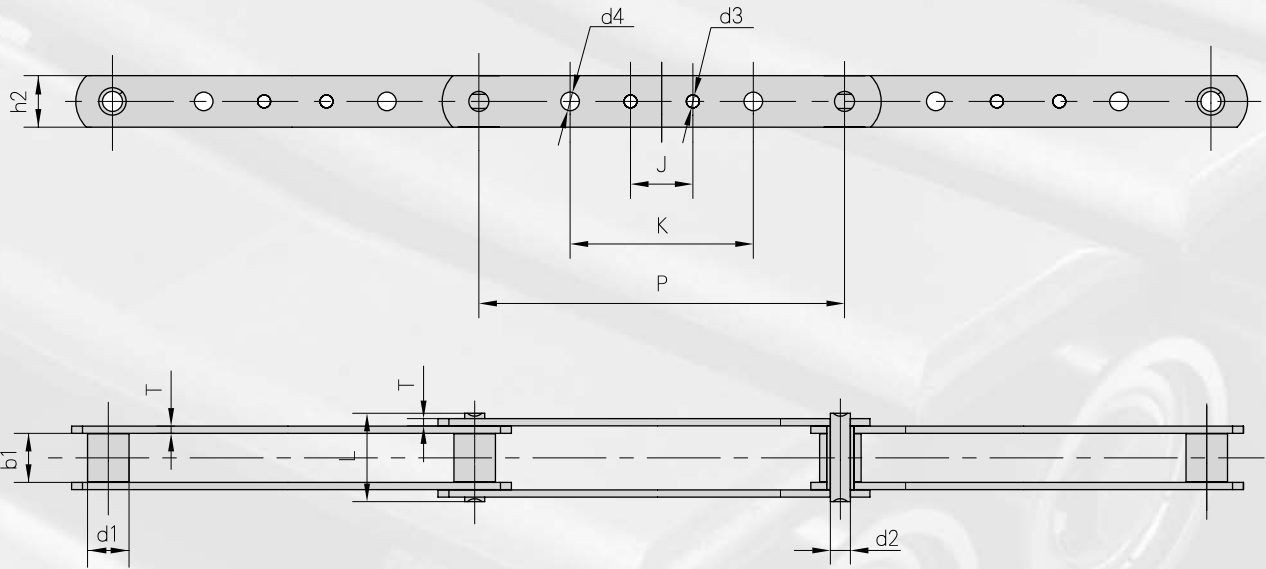

Flexon	Teilung	Rollen Ø	Lichte Weite	Bolzenab- messungen		Laschen- abmessungen					Laschen- dicke	min. Bruchkraft	Durchschn. Bruchlast	Gewicht per meter
Chain No.	Pitch	Roller diameter	Width between innerplates	Pin dimensions		Plate dimensions					Plate thick- ness	Ultimate tensile strength	Average tensile strength	Weight per meter
	P	d1 max	b1 min	d2 max	L max	h2 max	d3 max	d4 max	J max	K max	T max	Q min	Q0	q
	mm	mm	mm	mm	mm	mm	mm	mm	mm	mm	mm	kN/LB	kN	kg/m
3939-B4	203,2	23,00	27,00	11,1	49,0	28,58	7,2	7,2	38,1	101,6	4,0	115,58/26268	136,5	2,45
3939-B21	203,2	23,00	27,00	11,1	49,0	28,58	7,2		38,1		4,0	115,58/26268	136,5	2,45
3939-B23	203,2	23,00	27,00	11,1	49,0	28,58		10,3		92,1	4,0	115,58/26268	136,5	2,45
3939-B24	203,2	23,00	27,00	11,1	49,0	28,58		7,2		101,6	4,0	115,58/26268	136,5	2,45
3939-B40	203,2	23,00	27,00	11,1	49,0	28,58		10,3		101,6	4,0	115,58/26268	136,5	2,45
3939-B43	203,2	23,00	27,00	11,1	49,0	28,58	7,2	10,3	38,1	92,1	4,0	115,58/26268	136,5	2,45
3939-B44	203,2	23,00	27,00	11,1	49,0	28,58	7,2	10,3	38,1	101,6	4,0	115,58/26268	136,5	2,45



Verzahnte Laschen für Rollenketten nach DIN 8187 und 8188

Saw tooth plates for Roller chains acc. to DIN 8187 and 8188

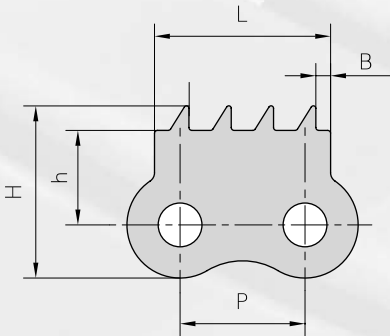

Flexon Chain No.	P	h	H	B	L
	mm	mm	mm	mm	mm
08B-940	12,7	9,6	17,5	1,5	17,9

C16AF1

C16AF2

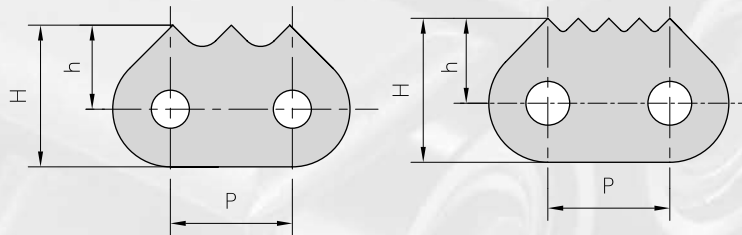

Flexon Chain No.	p	h	H
	mm	mm	mm
C16AF1	25,4	17,5	29,5
C16AF2	25,4	17,5	29,5

C60F2

60-910

12BF3

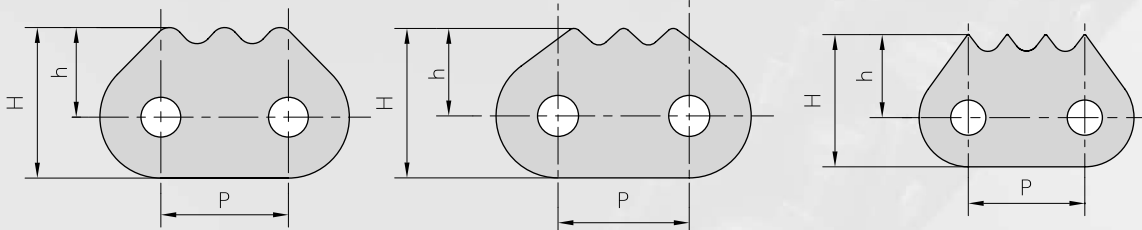

Flexon Chain No.	P	h	H
	mm	mm	mm
C60F2	19,05	13,38	22,48
60-910	19,05	12,70	21,70
12BF3	19,05	13,50	21,50



Verzahnte Laschen für Rollenketten nach DIN 8187 und 8188

Saw tooth plates for Roller chains acc. to DIN 8187 and 8188

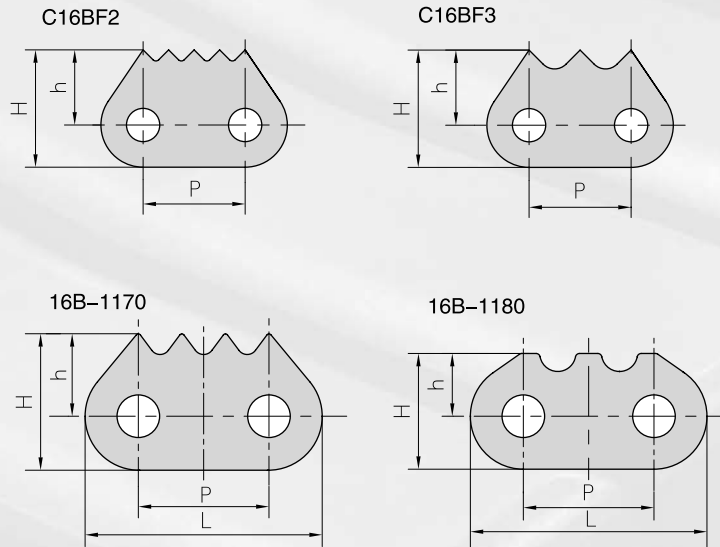

Flexon Chain No.	P	L	h	H
	mm	mm	mm	mm
C16BF2	25,4		18,7	29,2
C16BF3	25,4		18,7	29,2
16B-1170	25,4	46,1	16,0	26,5
16B-1180	25,4	46,0	12,2	22,5

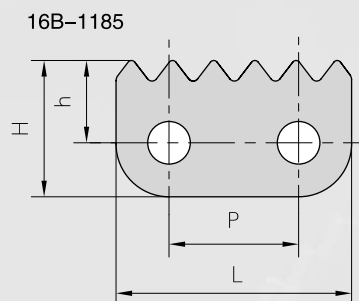

Flexon Chain No.	P	L	h	H
	mm	mm	mm	mm
16B-1185	25,4	46,0	16,0	26,5



Verzahnte Laschen für Rollenketten nach DIN 8187 und 8188

Saw tooth plates for Roller chains acc. to DIN 8187 and 8188

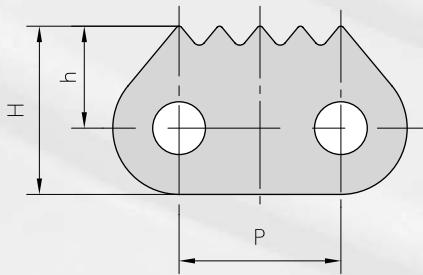

Flexon Chain No.	P	h	H
	mm	mm	mm
16BF24	25,4	16,0	26,4

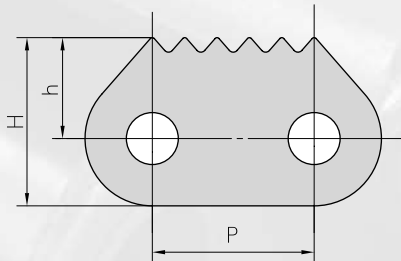

Flexon Chain No.	P	h	H
	mm	mm	mm
20BF8	31,75	19,8	33

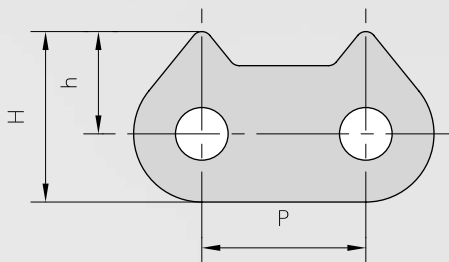

Flexon Chain No.	P	h	H
	mm	mm	mm
20B-1350	31,75	19,8	33



Verzahnte Laschen für Rollenketten nach DIN 8187 und 8188

Saw tooth plates for Roller chains acc. to DIN 8187 and 8188

Förderketten für
Spezialanwendung

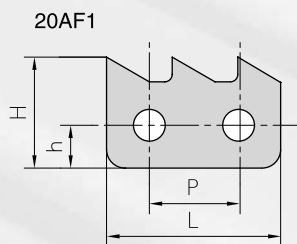

Flexon Chain No.	P	L	h	H
	mm	mm	mm	mm
20AF1	31,75	57,2	14,75	35,84

Flexon Chain No.	P	L	h	H
	mm	mm	mm	mm
120-1802	38,1	73,1	21,0	38,5

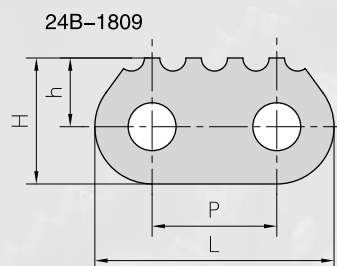
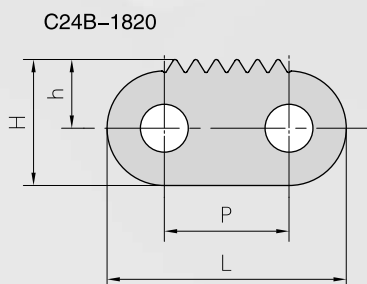
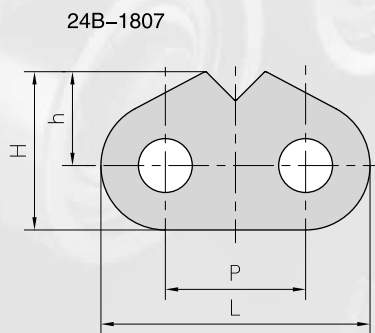
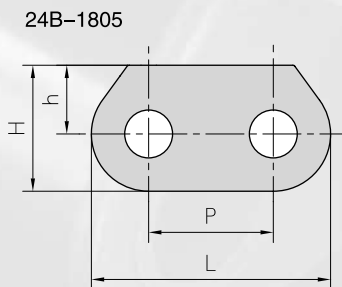
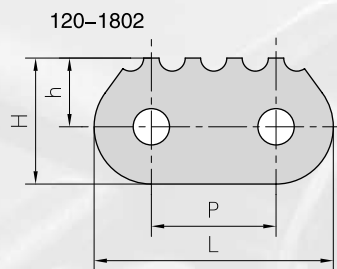

Flexon Chain No.	P	L	h	H
	mm	mm	mm	mm
24B-1805	38,1	73,1	21,0	38,5
24B-1807	38,1	73,1	25,5	43,0
24B-1809	38,1	73,1	21,0	38,5
C24B-1820	38,1	73,1	21,0	38,5



Verzahnte Laschen für Rollenketten nach DIN 8187 und 8188

Saw tooth plates for Roller chains acc. to DIN 8187 and 8188

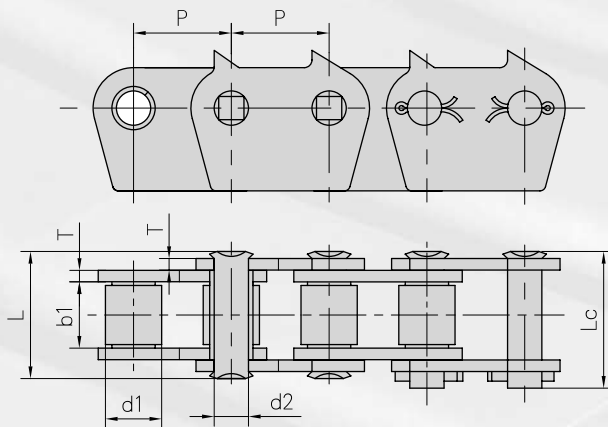

Flexon	Teilung	Rollen Ø	Lichte Weite	Bolzen Ø	Bolzenlänge		Laschen- dicke	min. Bruchkraft	Durchschn. Bruchlast	Gewicht per meter
Chain No.	Pitch	Roller diameter	Width between inner plates	Pin diameter	Pin length		Plate thickness	Ultimate tensile strength	Average tensile strength	Weight per meter
	P	d1 max	b1 min	d2 max	L max	Lc max	T max	Q min	Q0	q
	mm	mm	mm	mm	mm	mm	mm	kN/LB	kN	kg/m
32B-1-1872	50,8	29,21	33,0	17,81	66,0	71,0	6,0	250,0/56818	275,0	13,54

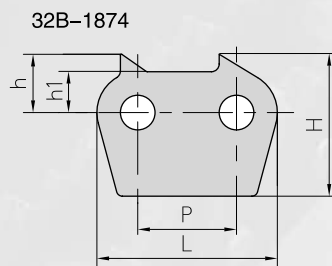
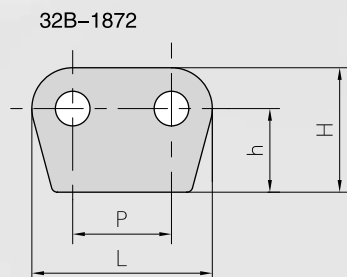

Flexon Chain No.	P	L	h i	h	H
	mm	mm	mm	mm	mm
32B-1872	50,8	92,8		43,0	64,0
32B-1874	50,8	92,8	21,0	30,0	73,0



Förderketten mit verzahnten Laschen nach Werksnorm

Conveyor chains with saw tooth links acc. to Industry standard

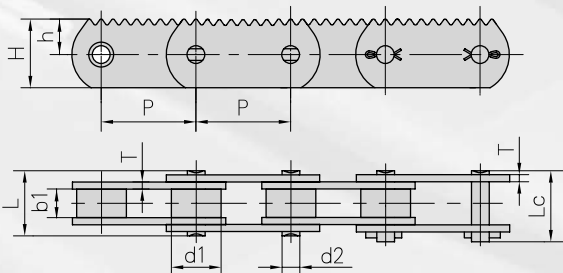

Flexon Chain No.	P	h	H
	mm	mm	mm
P80	80,0	30	58

Flexon Chain No.	Teilung Pitch	Rollen Ø Roller diameter	Lichte Weite Width between inner plates	Bolzen Ø Pin diameter	Bolzenlänge Pin length		Laschen- dicke Plate thick-ness	min. Bruchkraft Ultimate tensile strength	Durchschn. Bruchlast Average tensile strength	Gewicht per meter Weight per meter
	P	d1 max	b1 min	d2 max	L	Lc max	T max	Q min	q	
	mm	mm	mm	mm	mm	mm	mm	mm	kN/LB	kg/m
P80	80,0	42,0	24,0	15,0	55,0	60,0	6,0	250,0/56818	275,0	

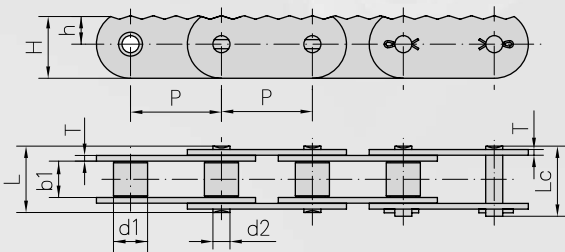

Flexon Chain No.	P	h	H
	mm	mm	mm
P80F3	80,0	25	55

Flexon Chain No.	Teilung Pitch	Rollen Ø Roller diameter	Lichte Weite Width between inner plates	Bolzen Ø Pin diameter	Bolzenlänge Pin length		Laschen- dicke Plate thick-ness	min. Bruchkraft Ultimate tensile strength	Durchschn. Bruchlast Average tensile strength	Gewicht per meter Weight per meter
	P	d1 max	b1 min	d2 max	L max	Lc max	T max	Q min	Qo	q
	mm	mm	mm	mm	mm	mm	mm	mm	kN/LB	kN
P80F3	80,0	30,0	32,0	15,0	58,6	62,6	5,0	98,0/20909	107,0	9,12



Traglaschenkette mit verzahnten Laschen

Saw tooth chains (Timber industry)

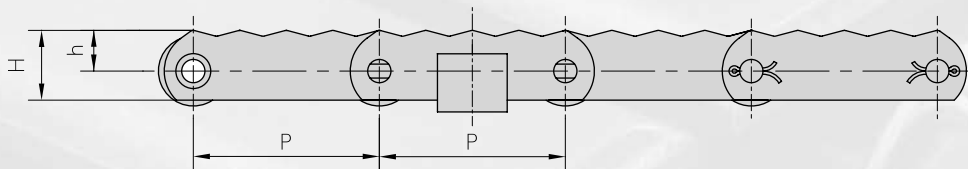
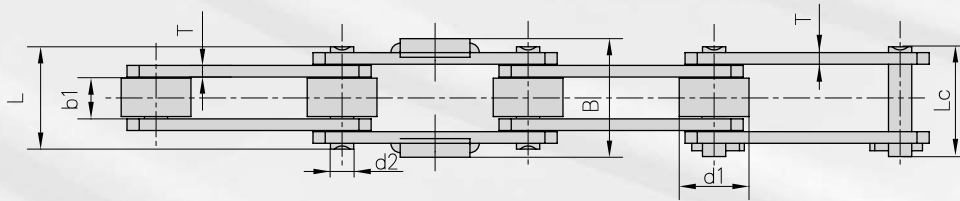

Flexon Chain No.	P	h	H	B
	mm	mm	mm	mm
P80F2	80,0	17,5	30,0	51

Flexon Chain No.	Teilung	Rollen Ø	Lichte Weite	Bolzen Ø	Bolzen- länge		Laschen- dicke	min. Bruchkraft	Durchschn. Bruchlast	Gewicht per meter
	Pitch	Roller diameter	Width between inner plates	Pin diameter	Pin length		Plate thick- ness	Ultimate tensile strength	Average tensile strength	Weight per meter
	P	d1 max	b1 min	d2 max	L max	Lc max	T max	Q min	Qo	q
	mm	mm	mm	mm	mm	mm	mm	kN/LB	kN	kg/m
P80F2	80,0	30,0	18,0	10,0	44,6	48,3	5,0	61,74/14030	70,0	4,15



Rollenketten mit aufvulkanisiertem Gummiprofil

Roller chains with vulcanised elastomer profiles

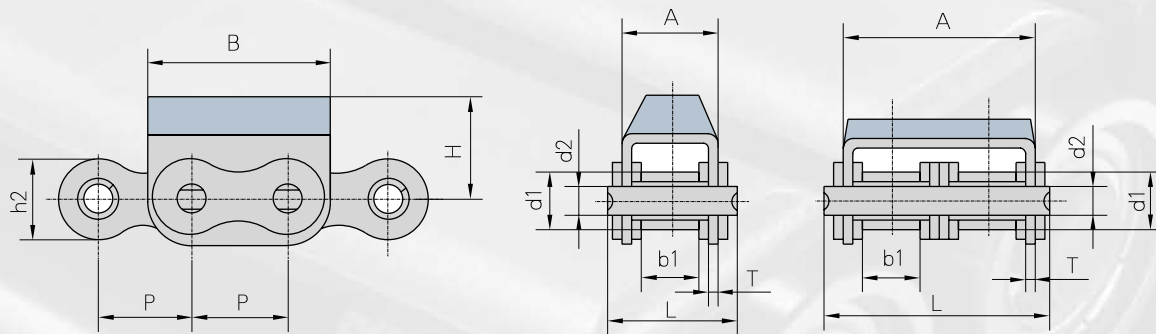

Flexon Chain No.	Teilung	Rollen Ø	Lichte Weite	Bolzen Ø	Bolzen- länge	Laschen- und Anbauteile- abmessungen					min. Bruchkraft	Gewicht per meter
	Pitch	Roller diameter	Width between inner plates	Pin diameter	Pin length	Plate and attachment dimension					Ultimate tensile strength	Weight per meter
	P	d1 max	b1 min	d2 max	L max	h2 max	A	B	H	T	Q min	q
	mm	mm	mm	mm	mm	mm	mm	mm	mm	mm	kN/LB	kg/m
08B-G1	12,70	8,51	7,75	4,45	20,0	11,8	14,6	24,2	12,3	1,60	18,0/4091	1,19
08B-G2	12,70	8,51	7,75	4,45	34,3	11,8	28,4	24,2	12,3	1,50	32,0/7273	2,07
10B-G1	15,88	10,16	9,65	5,08	23,2	14,7	16,8	30,0	17,0	1,60	19,0/4318	1,62
10B-G2	15,88	10,16	9,65	5,08	39,7	14,7	33,3	30,0	17,0	1,50	44,5/10114	2,56
12B-G1	19,05	12,07	11,68	5,72	25,7	16,0	19,6	36,0	21,0	1,85	29,0/6591	2,01
12B-G2	19,05	12,07	11,68	5,72	45,3	16,0	39,1	36,0	16,0	1,85	57,8/13136	3,21
16A-G1	25,40	15,88	15,75	7,92	37,2	24,0	27,5	46,0	20,0	2,42	42,0/9545	3,97
16B-G1	25,40	15,88	17,02	8,28	39,7	21,0	29,1	49,0	21,4	1,60	58,0/13047	3,83
20B-G1	31,75	19,05	19,56	10,19	48,0	26,4	36,0	57,0	27,0	3,50	85,0/19318	6,19
24B-G1	38,10	25,40	25,40	14,63	61,6	33,2	47,0	72,6	34,0	4,50	160,0/36363	11,25



Rollenketten mit aufvulkanisiertem Gummiprofil

Roller chains with vulcanised elastomer profiles

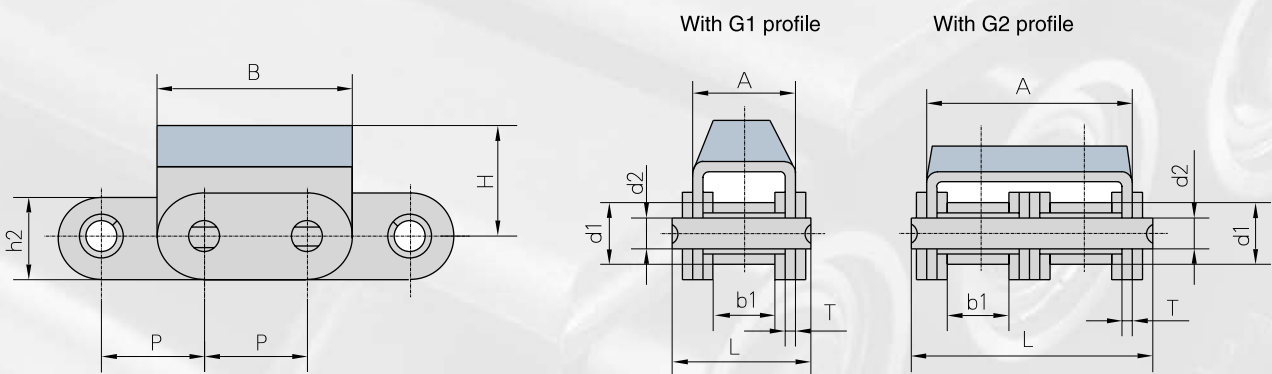

Flexon	Teilung	Rollen Ø	Lichte Weite	Bolzen Ø	Bolzen- länge	Laschen- und Anbauteile- abmessungen					min. Bruchkraft	Gewicht per meter
Chain No.	Pitch	Roller diameter	Width between inner plates	Pin diameter	Pin length	Plate and attachment dimension					Ultimate tensile strength	Weight per meter
	P	d1 max	b1 min	d2 max	L max	h2 max	A	B	H	T	Q min	q
	mm	mm	mm	mm	mm	mm	mm	mm	mm	mm	kN/LB	kg/m
C08B-G1	12,70	8,51	7,75	4,45	20,0	11,8	14,6	24,2	12,3	1,60	18,0/4091	1,30
C08B-G2	12,70	8,51	7,75	4,45	34,3	11,8	28,4	24,2	12,3	1,50	32,0/7273	2,29
C10B-G1	15,88	10,16	9,65	5,08	23,2	14,7	16,8	30,0	17,0	1,60	19,0/4318	1,75
C10B-G2	15,88	10,16	9,65	5,08	39,7	14,7	33,3	30,0	17,0	1,50	44,5/10114	2,95
C12B-G1	19,05	12,07	11,68	5,72	25,7	16,0	19,6	36,0	21,0	1,85	29,0/6591	2,15
C12B-G2	19,05	12,07	11,68	5,72	45,3	16,0	39,1	36,0	16,0	1,85	57,8/13136	3,48
C16A-G1	25,40	15,88	15,75	7,92	37,2	24,0	27,5	46,0	20,0	2,42	42,0/9545	4,34
C16B-G1	25,40	15,88	17,02	8,28	39,7	21,0	29,1	49,0	21,4	1,60	58,0/13047	4,11
C20B-G1	31,75	19,05	19,56	10,19	48,0	26,4	36,0	57,0	27,0	3,50	85,0/19318	6,65
C24B-G1	38,10	25,40	25,40	14,63	61,6	33,2	47,0	72,6	34,0	4,50	160,0/36363	11,63



Rollenketten mit aufvulkanisiertem Gummiprofil

Roller chains with vulcanised elastomer profiles

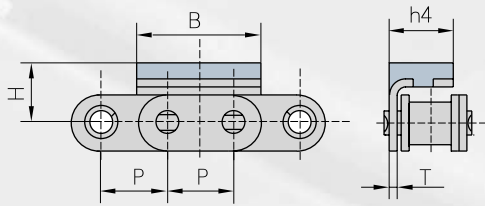

Flexon Chain No.	P	B	H	h4	T
	mm	mm	mm	mm	mm
06BF9	9,525	17,73	9,0	9,05	1,3

Flexon Chain No.	P	A	B	H	T
	mm	mm	mm	mm	mm
08B-G1F1	12,7	18,0	24,2	12,3	1,6

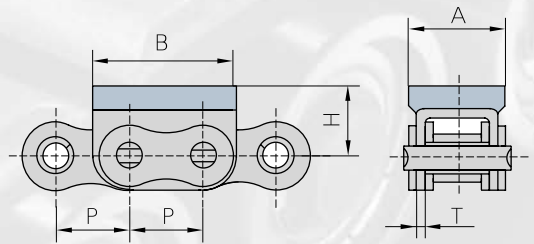

Flexon Chain No.	P	A	B	H	T
	mm	mm	mm	mm	mm
08B-G1 F4	12,7	18,0	24,2	12,3	1,6

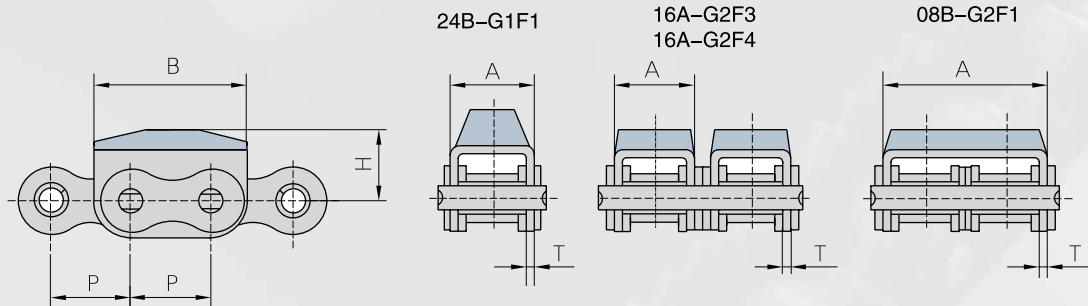
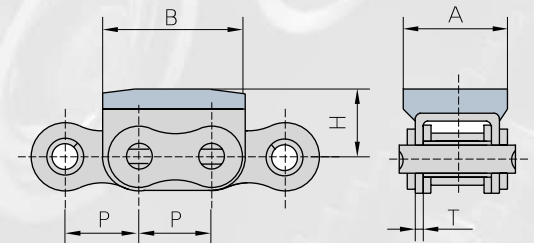

Flexon Chain No.	P	A	B	H	T
	mm	mm	mm	mm	mm
08B-G2F1	12,7	28,4	24,2	12,0	1,5
16A-G2F3	25,4	27,5	49,0	21,4	2,42
16A-G2F4	25,4	27,0	49,2	20,0	2,03
24B-G1 F1	38,1	47,0	72,6	34,0	4,5



Rollenketten mit aufvulkanisiertem Gummiprofil

Roller chains with vulcanised elastomer profiles

Flexon Chain No.	P	A	B	H	T
	mm	mm	mm	mm	mm
12B-G1F1	19,05	19,6	36,0	18,0	1,85

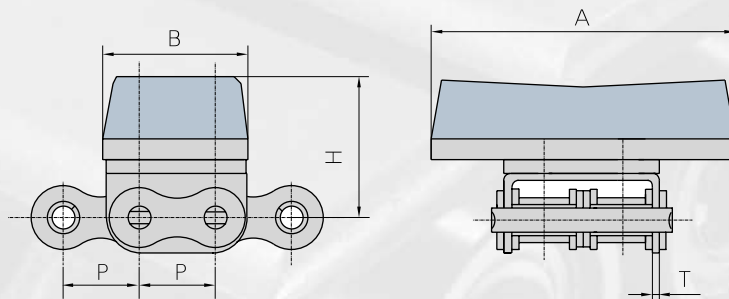
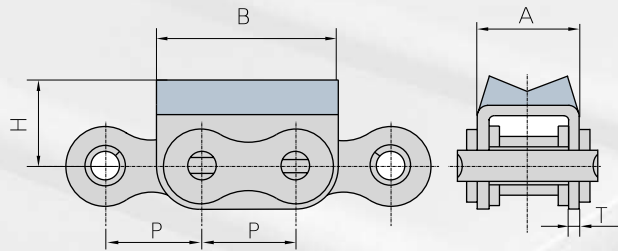

Flexon Chain No.	P	A	B	H	T
	mm	mm	mm	mm	mm
12B-G2F3	19,05	77,0	37,0	36,0	1,85

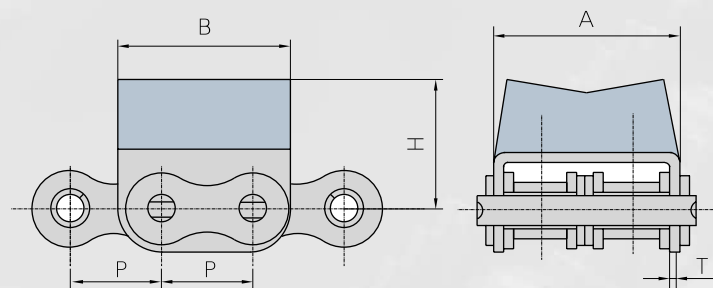

Flexon Chain No.	P	A	B	H	T
	mm	mm	mm	mm	mm
12B-G2F4	19,05	39,1	36,0	27,5	1,85



Rollenketten mit aufvulkanisiertem Gummiprofil

Roller chains with vulcanised elastomer profiles

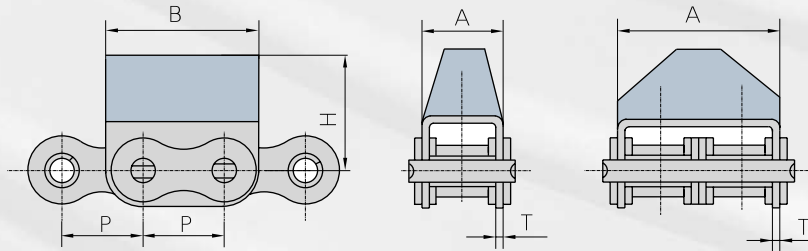

Flexon Chain No.	P	A	B	H	T
	mm	mm	mm	mm	mm
12B-G2F5	19,05	39,1	36,0	28,0	1,85
16A-G1F1	25,40	27,5	46,0	21,4	2,42

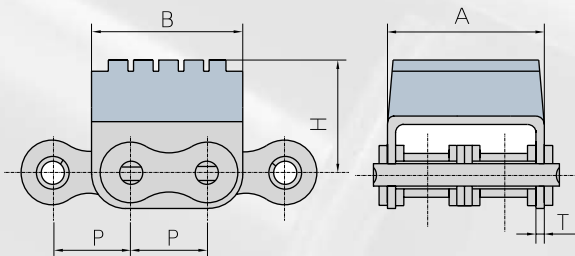

Flexon Chain No.	P	A	B	H	T
	mm	mm	mm	mm	mm
12B-G2F6	19,05	39,1	37,3	28,2	1,85

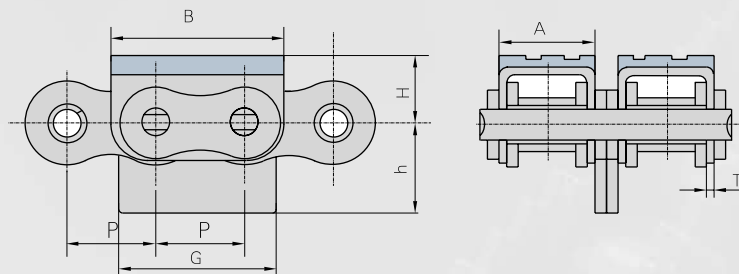

Flexon Chain No.	P	A	B	G	h	H	T
	mm	mm	mm	mm	mm	mm	mm
16A-G2F1	25,4	27,0	49,2	45,4	25,0	20,0	2,03



Rollenketten mit aufvulkanisiertem Gummiprofil

Roller chains with vulcanised elastomer profiles

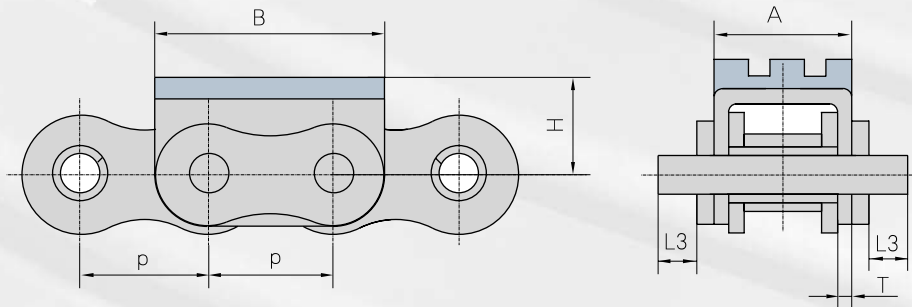

Flexon Chain No.	P	A	B	L3	H	T
	mm	mm	mm	mm	mm	mm
16A-G1F3	25,4	27,5	49,0	8,25	21,4	2,42

Rollenketten mit Sonderanbauteilen, U-Bügel mit Gewindeeinsatz

Roller chains with U type attachments

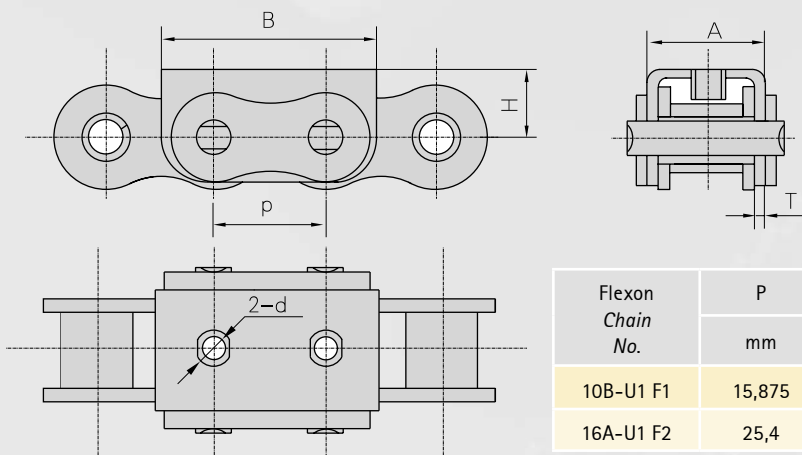

Flexon Chain No.	P	A	B	d	H	T
	mm	mm	mm	mm	mm	mm
10B-U1 F1	15,875	16,8	30,0	M5	11,3	1,6
16A-U1 F2	25,4	27,3	49,5	M6	16,45	2,3



Rollenketten mit Sonderanbauteilen, U-Bügel U1 und U2

Roller chains with U type attachments

Förderketten für
Spezialanwendung

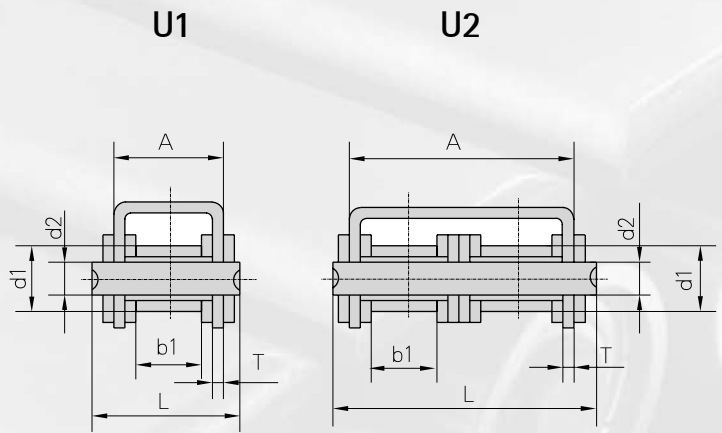
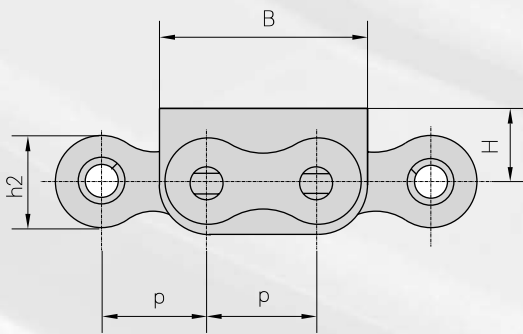

Flexon	Teilung	Rollen Ø	Lichte Weite	Bolzen Ø	Bolzenlänge	Laschen- und Anbauteile-abmessungen					min. Bruchkraft	Gewicht per meter
Chain No.	Pitch	Roller diameter	Width between inner plates	Pin diameter	Pin length	Plate and attachment dimension					Ultimate tensile strength	Weight per meter
	P	d1 max	b1 min	d2 max	L max	h2 max	A	B	H	T	Q min	q
	mm	mm	mm	mm	mm	mm	mm	mm	mm	mm	kN/LB	kg/m
08B-U1	12,70	8,51	7,75	4,45	20,0	11,8	14,6	24,2	8,3	1,60	18,0/4091	1,13
08B-U2	12,70	8,51	7,75	4,45	34,3	11,8	28,4	24,2	8,3	1,50	32,0/7273	1,96
10B-U1	15,88	10,16	9,65	5,08	23,2	14,7	16,8	30,0	11,3	1,60	19,0/4318	1,53
10B-U2	15,88	10,16	9,65	5,08	39,7	14,7	33,3	30,0	11,3	1,50	44,5/10114	2,47
12B-U1	19,05	12,07	11,68	5,72	25,7	16,0	19,6	36,0	13,0	1,85	29,0/6591	1,90
12B-U2	19,05	12,07	11,68	5,72	45,3	16,0	39,1	36,0	12,0	1,85	57,8/13136	3,03
16A-U1	25,40	15,88	15,75	7,92	37,2	24,0	27,5	46,0	16,0	2,42	42,0/9545	3,87
16B-U1	25,40	15,88	17,02	8,28	39,7	21,0	29,1	49,0	15,4	1,60	58,0/13407	3,73
20BF2	31,75	19,05	19,56	10,19	48,0	26,4	36,0	57,0	21,0	3,50	85,0/19318	6,01
24B-U1	38,10	25,40	25,40	14,63	61,6	33,2	47,0	72,6	28,0	4,50	160,0/36363	10,88



Rollenketten mit Sonderanbauteilen, U-Bügel U2 mit 2 Bohrungen

Roller chains with U type attachments U2 with 2 holes

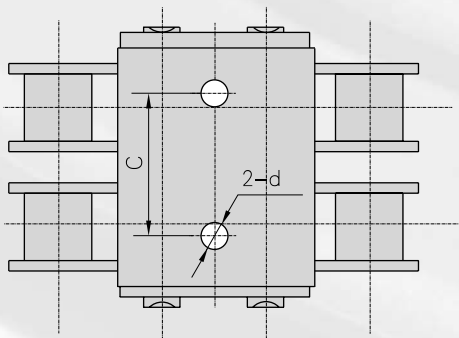
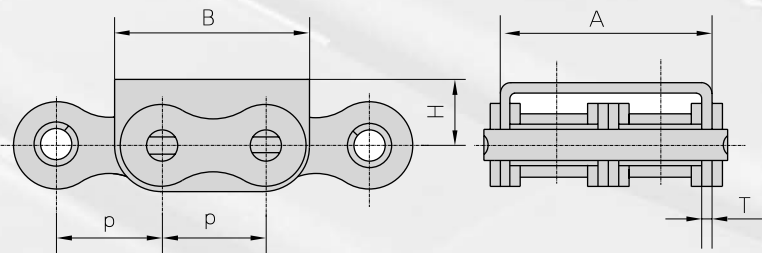

Flexon Chain No.	P	A	B	C	d	H	T
	mm	mm	mm	mm	mm	mm	mm
08B-U2F2	12,7	28,4	24,2	17,5	3,3	8,3	1,5

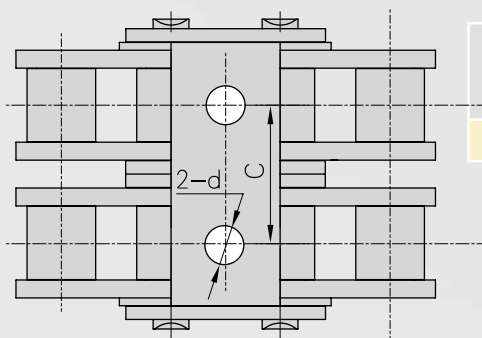
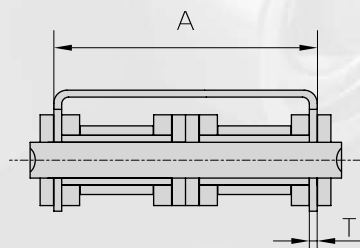
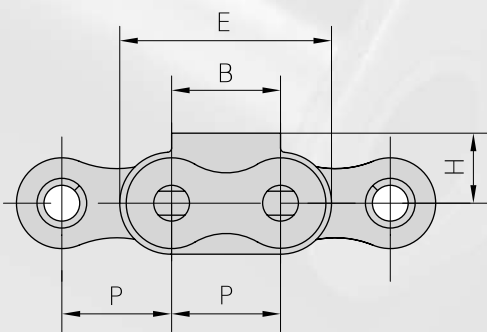

Flexon Chain No.	P	A	B	C	d	E	H	T
	mm	mm	mm	mm	mm	mm	mm	mm
16B-U2F1	25,4	60,93	25,0	33,5	9,0	49,0	16,2	1,6



Rollenketten mit Traglaschen aus Kunststoff

Roller chains with Plastic conveyor links

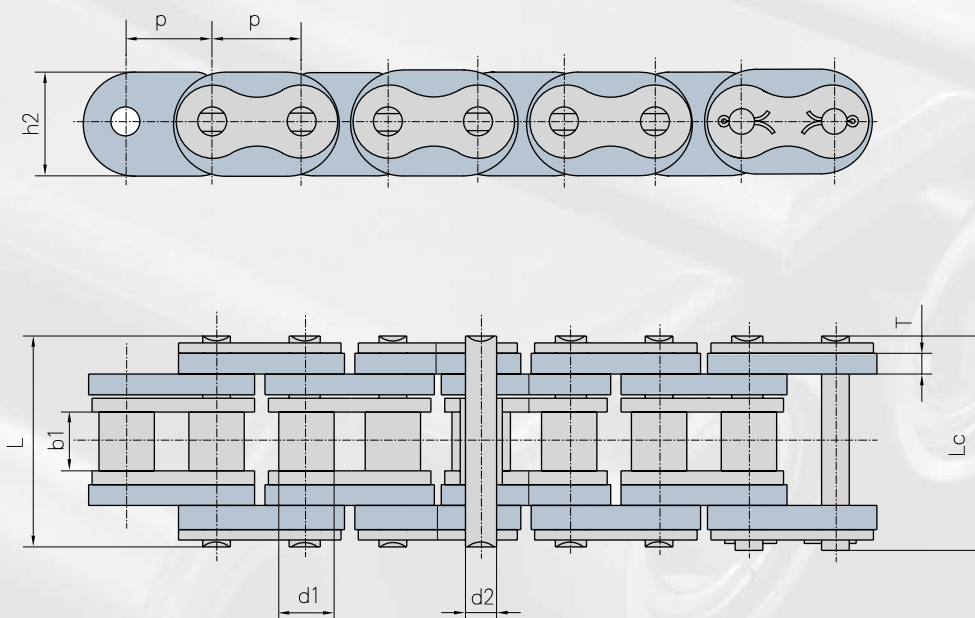

Flexon	Teilung	Rollen Ø	Lichte Weite	Bolzen Ø	Bolzen- länge		Laschen- und Anbauteile- abmessungen		min. Bruchkraft	Gewicht per meter
Chain No.	Pitch	Roller diameter	Width between inner plates	Pin diameter	Pin length		Plate and attachment dimension		Ultimate tensile strength	Weight per meter
	P	d1 max	b1 min	d2 max	L max	Lc max	h2	T	Q min	q
	mm	mm	mm	mm	mm	mm	mm	mm	kN/LB	kg/m
16BF9	25,4	15,88	17,02	8,28	61,0	64,2	30,0	6,0	22,0/4949	3,7



Rollenketten mit Traglaschen aus Kunststoff

Roller chains with Plastic conveyor links

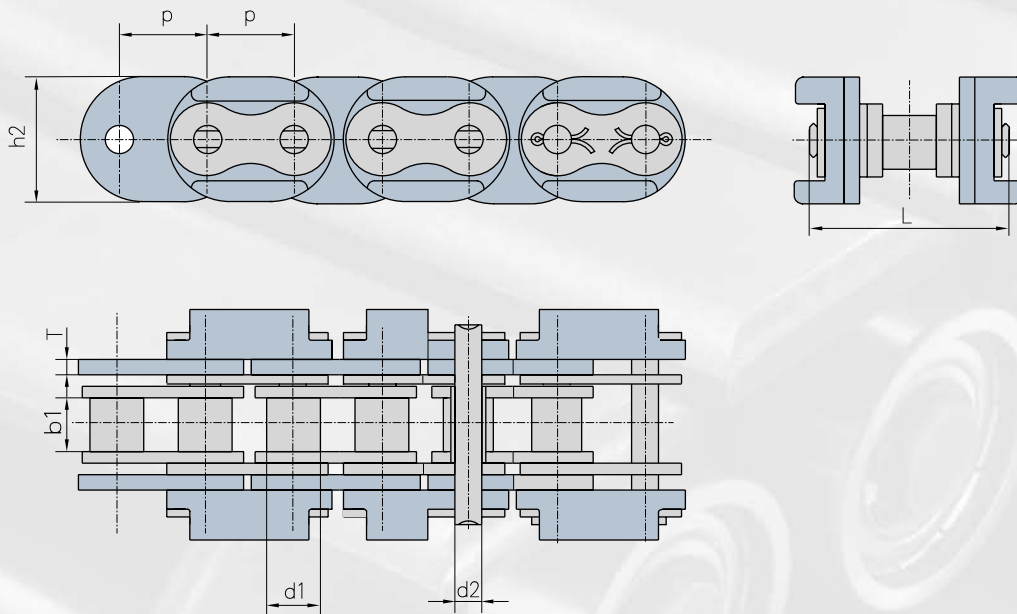

Flexon	Teilung	Rollen Ø	Lichte Weite	Bolzen Ø	Bolzen- länge	Laschen- und Anbauteile- abmessungen		min. Bruchkraft	Gewicht per meter
Chain No.	Pitch	Roller diameter	Width between inner plates	Pin diameter	Pin length	Plate and attachment dimension		Ultimate tensile strength	Weight per meter
	P	d1 max	b1 min	d2 max	L max	h2 max	T	Q min	q
	mm	mm	mm	mm	mm	mm	mm	kN/LB	kg/m
20BF6	31,75	19,05	19,56	10,19	73,7	45,0	6,0	95,0/21591	6,35



Rollenketten mit Kunststoff-Rollen

Roller chains with Plastic rollers

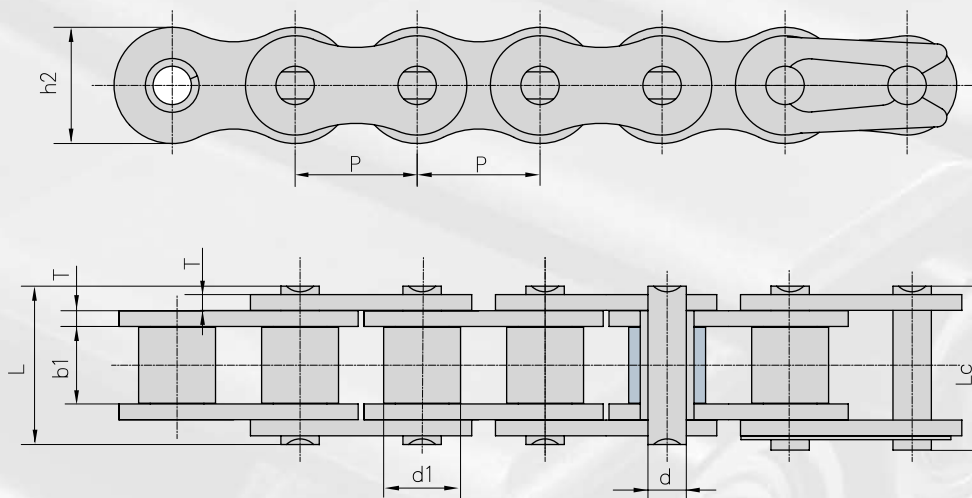

Flexon	Teilung	Rollen Ø	Lichte Weite	Bolzen Ø	Bolzen- länge		Höhe Innen- lasche	Laschen- dicke	min. Bruchkraft	Durchschn. Bruchlast	Gewicht per meter
Chain No.	Pitch	Roller diameter	Width between inner plates	Pin diameter	Pin length		Inner plate depth	Plate thick- ness	Ultimate tensile strength	Average tensile strength	Weight per meter
	P	d1 max	b1 min	d2 max	L max	Lc max	h2 max	T	Q min	Q	q
	mm	mm	mm	mm	mm	mm	mm	mm	kN/LB	kN	kg/m
40-P	12,700	7,95	7,85	3,96	16,60	17,80	12,00	1,50	14,10/3205	17,5	0,56
50-P	15,875	10,16	9,4	5,08	20,70	22,20	15,09	2,03	22,20/5045	29,4	0,96
60-P	19,050	11,91	12,57	5,94	25,90	27,70	18,00	2,42	31,80/7227	41,5	1,35
80-P	25,400	15,88	15,75	7,92	32,70	35,00	24,00	3,25	56,70/12886	69,4	2,26
A2050-P	31,750	10,16	9,40	5,08	20,70	22,20	15,00	2,03	22,2/5045	28,1	0,61



Rollenketten mit Tragplatten aus Kunststoff

Roller chains with Plastic Top plates

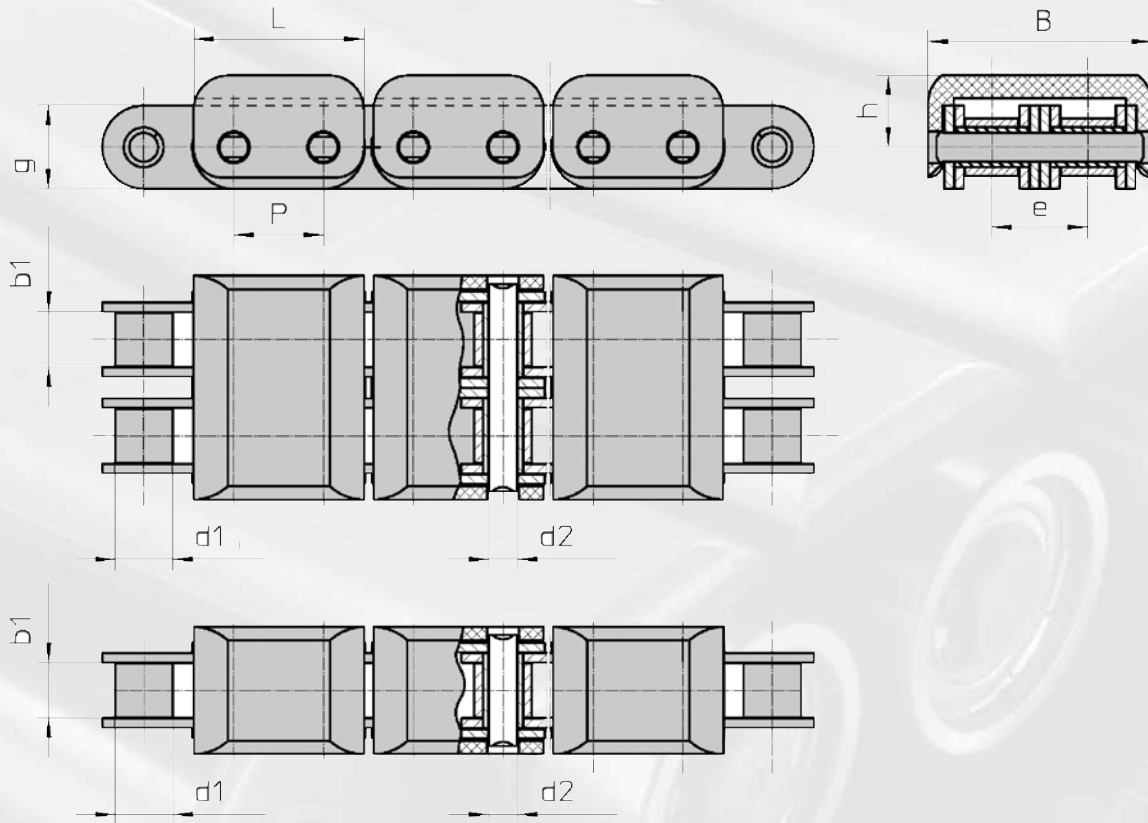

Flexon	Teilung	Lichte Weite	Rollen Ø	Bolzen Ø	Laschenhöhe	Mittenmass	Länge Clip	Höhe	Breite	Tragfähigkeit pro Tragplatte	Durchschn. Bruchlast
Chain No.	Pitch	Width between inner plates	Roller diameter	Pin diameter	Plate depth	Transverse	Clip length	Height	Width	Load capacity per clip	Average tensile strength
	P	b1 min	d1 max	d2 max	g max	e	L	h	B		Q0
	mm	mm	mm	mm	mm	mm	mm	mm	mm	kg	kN
C 08 B-1 KC	12,7	7,75	8,51	4,45	11,8	-	21,9	9,3	19,7	70	18,000
C 08 B-2 KC	12,7	7,75	8,51	4,45	11,8	13,92	21,9	9,3	33,7	140	32,000
C 10 B-1 KC	15,875	9,65	10,16	5,08	14,7	-	30,0	12,5	22,5	90	22,400
C 10 B-2 KC	15,875	9,65	10,16	5,08	14,7	16,59	30,0	12,5	39,3	180	44,500
C 12 B-1 KC	19,05	11,68	12,07	5,72	16,1	-	34,2	13,2	25,4	110	29,000
C 12 B-2 KC	19,05	11,68	12,07	5,72	16,1	19,46	34,2	13,2	45,3	220	57,800
C 16 B-1 KC	25,4	17,02	15,88	8,28	21	-	45,7	18,5	40,9	140	60,000
C 16 B-2 KC	25,4	17,02	15,88	8,28	21	31,88	45,7	18,5	72,8	280	106,000
C 20 B-1 KC	31,75	19,56	19,05	10,19	26,4	-	53,4	23,2	47,0	180	95,000
C 20 B-2 KC	31,75	19,56	19,05	10,19	26,4	36,45	53,4	23,2	83,45	360	170,000



Rollenketten mit Traglaschen aus Kunststoff (Transfer-Kette)

Roller chains with Plastic Top plates (Transfer chain)

Förderketten für
Spezialanwendung

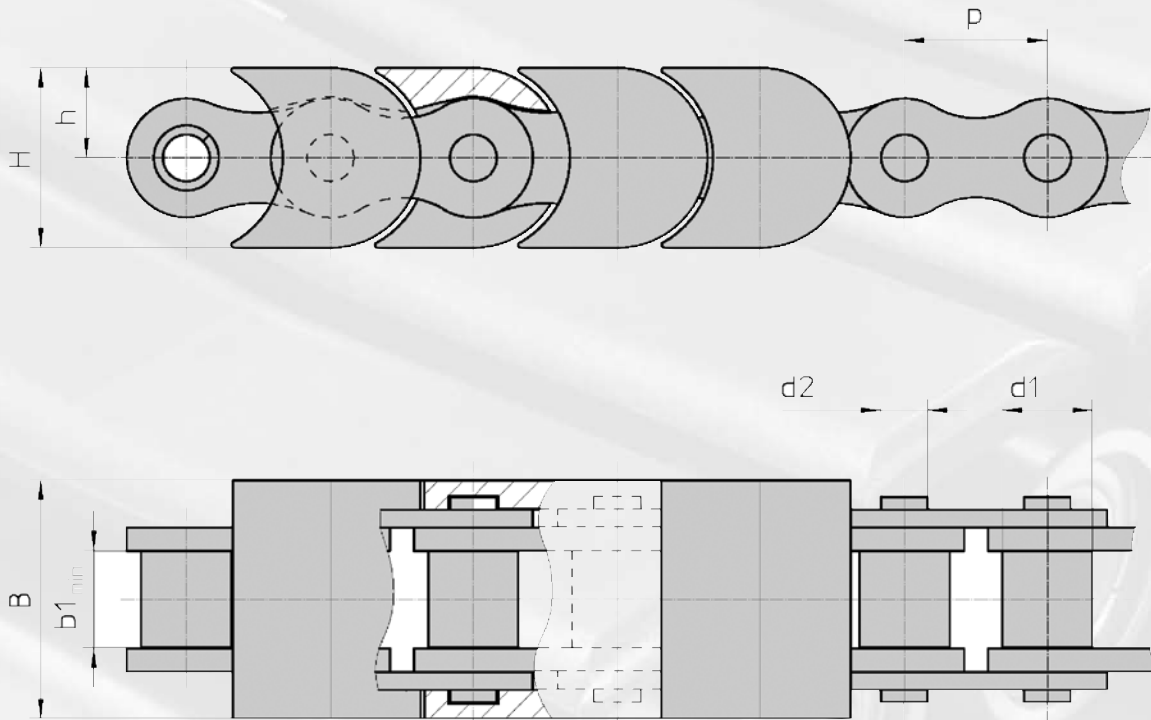

Flexon	Teilung	Lichte Weite	Rollen Ø	Bolzen Ø	Höhe H	Breite	Höhe h	max. Belastung je Kunststoffbügel	Durchschn. Bruchlast
Chain No.	Pitch	Width between inner plates	Roller diameter	Pin diameter	Height H	Width	Height h	max. load of plastic clip	Average tensile strength
	P	b1 min	d1 max	d2 max	H	B	h	kg	Q ₀
	mm	mm	mm	mm	mm	mm	mm		kN
08 B-1 TFK	12,7	7,75	8,51	4,45	19,8	15,2	8,0	12	18,000
10 B-1 TFK	15,875	9,65	10,16	5,08	24,8	17,5	9,5	25	22,400
12 B-1 TFK	19,05	11,68	12,07	5,72	29,8	19,8	11,0	43	29,000

Notizen

Notes

Förderketten für
Spezialanwendung



Auszüge aus dem aktuellen Gesamtkatalog, die als PDF-Dokument zum Download bereit stehen.

The following sections from our current catalogue can be downloaded in pdf-format:



Hochleistungsrollenketten
High precision roller chains
Stauförderketten
Accumulation Chains



Antriebsrollenketten
Transmission roller chains



Rollenketten für Förderaufgaben
Roller chains for conveying purposes
mit Teile- und Fingerschutz
with parts and finger protection



Flyerketten für Hubgeräte
Leaf Chains for Forklift-Trucks



Förderketten
Conveyor chains
Förderketten für Spezialanwendungen
Conveyor chains for special applications



Kurvengängige Platten-Förderketten
Sideflexing Plate Top Chains



Landmaschinenketten
Agricultural chains



Kettenräder
Sprockets

www.flexon.de

FLEXON GmbH
Essener Straße 23
D-57234 Wilnsdorf
Tel.: +49 (0) 27 39-86 0
Fax: +49 (0) 27 39-86 22

www.flexon.de | info@flexon.de

FLEXON GmbH, Sontra
Landmaschinenketten
Service-Center
Schützenweg 5
D-36205 Sontra
Tel.: +49 (0) 56 53-97 78-0
Fax: +49 (0) 56 53-97 78-26

FLEXON International
The Netherlands
Slotlaan 5
NL-1871 BC Schoorl
Tel.: +31 (0) 72-50 94 9-81
Fax: +31 (0) 72-50 94 9-97

FLEXON France I
France
741, ZAC des Longues Rayes
60610 Lacroix Saint Ouen
Tel.: +33 (0) 3- 44 91 23-19
Fax: +33 (0) 3- 44 91 23-22

FLEXON France II
France
10 Rue du Luxembourg
69330 Meyzieu
Tel.: +33 (0) 4-37 45 15-70
Fax: +33 (0) 4-37 45 15-71

FLEXON Ltd., UK
United Kingdom
Unit 8C Bloomfield Park
Bloomfield Road, Tipton
West Midlands DY4 9AP U.K.
Tel.: +44 (0) 12-15 21 36 00
Fax: +44 (0) 12-15 20 08 22

FLEXON USA LCC.
Indianapolis
3902 Hanna Circle, Suite F
Indianapolis, IN 56241
Tel.: +1 (0) 317 82 1-35 39
Fax: +1 (0) 317 82 1-35 69