

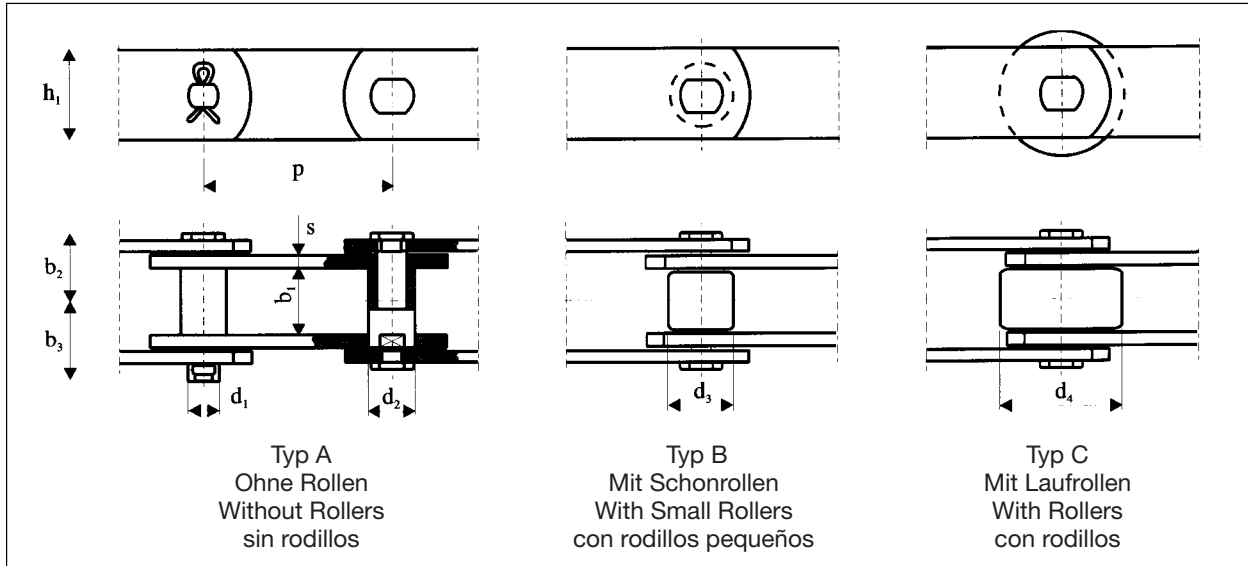

Förderketten



Förderketten nach DIN 8167 / M-Serie
Conveyor Chains DIN 8167 / M-Series
Cadenas de transporte DIN 8167 / Serie M

Ketten Nr.	Bruchkraft kN	Zulässige Belastung N	Teilung P				Lichte Weite b1	Bolzen d1	Buchse d2	Schonrolle d3	Laufrolle d4	Bundlaufrolle		b2	b3	Laschen			
												d5	e			s	h1	h2	h3
M 40	40	5700	63	80	100	125	20	8,5	12,5	18	36	42	13,5	21	24	4	25	35	22,5
M 56	56	8000	63	80	100	125	24	10	15	21	42	50	17	24	27	4	30	45	25
M 80	80	11400	80	100	125	160	28	12	18	25	50	60	20	29	33	5	35	50	32,5
M 112	112	16000	80	100	125	160	32	15	21	30	60	70	22	33	37	6	40	60	40
M 160	160	22800	100	125	160	200	37	18	25	36	70	85	25,5	38	43	7	50	70	45
M 224	224	32000	125	160	200	250	43	21	30	42	85	100	30	44	49	8	60	90	60
M 315	315	45000	160	200	250	315	48	25	36	50	100	120	33	51	58	10	70	100	65
M 450	450	64000	200	250	315	400	56	30	42	60	120	140	37	60	66	12	80	120	80
M 630	630	90000	250	315	400	500	66	36	50	70	140	170	45	69	78	14	100		
M 900	900	128000	250	315	400	500	78	44	60	85	170	210	52	79	89	16	120		

Andere Abmessungen auf Anfrage / Other dimensions on request / Otras dimensiones según consulta



Förderketten

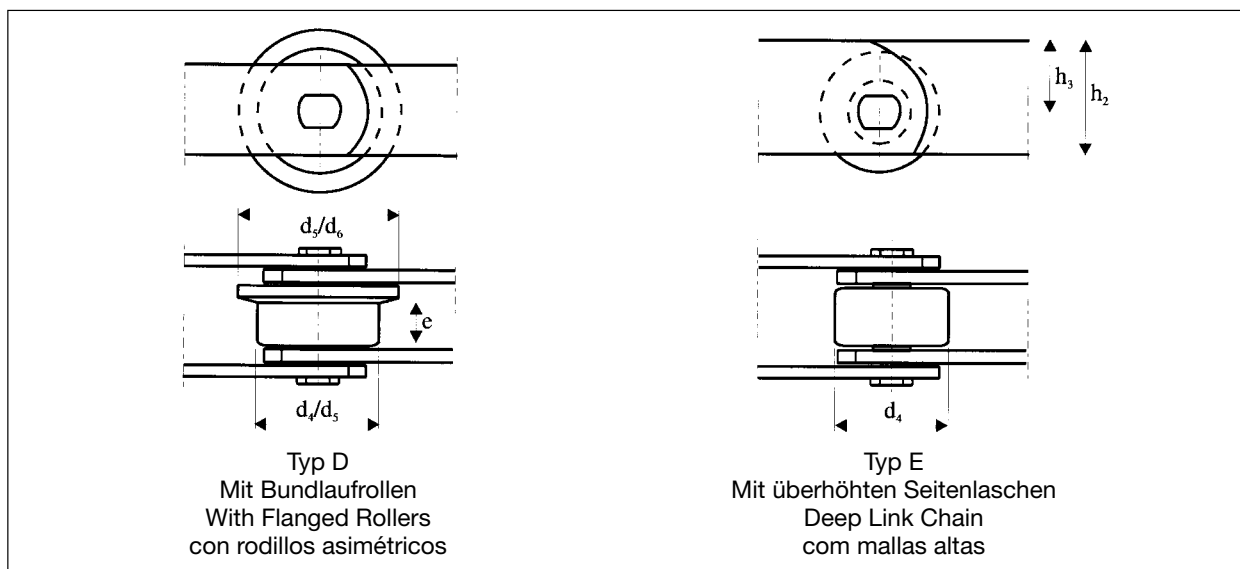

Förderketten nach DIN 8165 / FV-Serie
Conveyor Chains DIN 8165 / FV-Series
Cadenas de transporte DIN 8165 / Serie FV

Ketten Nr.	Bruchkraft kN	Zulässige Belastung N	Teilung P				Lichte Weite b1	Bolzen d1	Buchse d2	Schonrolle d3	Laufrolle d4	Bundlaufrolle		b2	b3	Laschen			
												d5	d6			s	h1	h2	h3
FV 40	40	6700	40	63	80	100	18	10	15	20	32	40	48	18,5	22	4	25	35	22
FV 63	63	10500	63	100	125	160	22	12	18	26	40	50	60	23	27,5	4	30	40	25
FV 90	90	15000	63	100	125	160	25	14	20	30	48	63	73	26,5	31	5	35	45	27,5
FV 112	112	18700	100	125	160	200	30	16	22	32	55	72	87	31,5	36	6	40	50	30
FV 140	140	23400	100	125	160	200	35	18	26	36	60	80	95	34	40	6	45	60	37,5
FV 180	180	30000	125	160	200	250	45	20	30	42	70	100	120	43	50	8	50	70	45
FV 250	250	41700	125	160	200	250	55	26	36	50	80	125	145	49	57	8	60	80	50
FV 315	315	52500	160	200	250	315	65	30	42	60	90	140	170	58,5	66,5	10	70	90	55
FV 400	400	66700	160	200	250	315	70	32	44	60	100	150	185	65,5	75,5	12	70	90	55
FV 500	500	83400	160	200	250	315	80	36	50	70	110	160	195	70,5	80,5	12	80	100	60
FV 630	630	105000	200	250	315	400	90	42	56	80	120	170	210	76,5	86,5	12	100	120	70

Andere Abmessungen auf Anfrage / Other dimensions on request / Otras dimensiones según consulta



Förderketten SMS 1698
Conveyor Chains SMS 1698
Cadenas SMS 1698

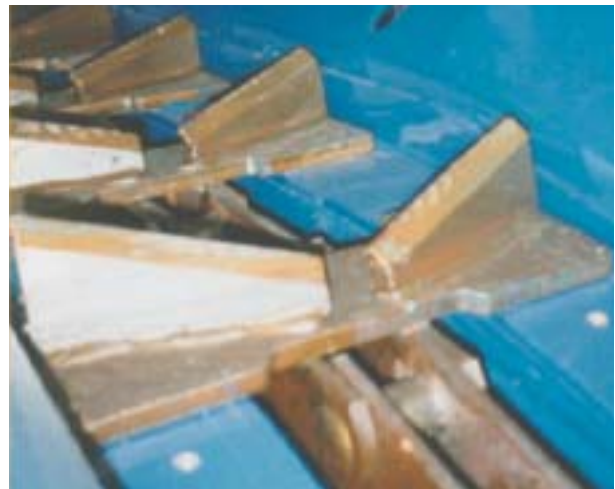
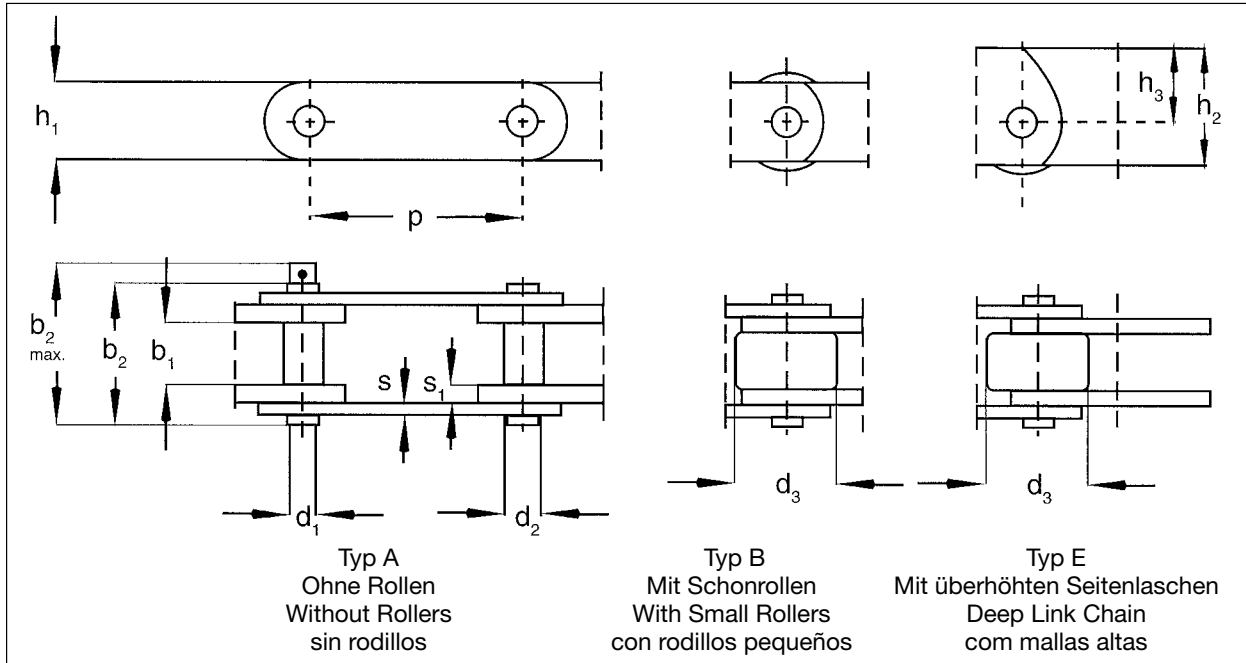

Chain Nr.	Breaking load kN	Pitch P mm				Inner width b1 mm	Pin d1 mm	Bush d2 mm	Roller d3 mm	Sideplates				Outer sideplates		Length of pin b2 mm
		50	63	80	100					h1 mm	h2 mm	h3 mm	s mm	s mm normal	s mm heavy	
3,5	35	50	63	80	100	18	10	15	32	25	35	22,5	4	4	6	49
5,5	55	50	63	80	100	22	12	18	40	30	40	25	5	4	6	54
8,5	85	63	80	100	150	25	14	20	50	35	50	32,5	6	5	8	65
12,5	125	100	150	200	250	35	18	26	60	40	60	40	8	6	8	81
18	180	100	150	200	250	45	20	30	70	50	78	45	8	6	10	96
24	240	100	150	200	250	55	26	36	80	60	80	50	10	8	12	116
30	300	150	200	250	300	65	30	42	90	70	90	55	10	8	12	128
40	400	150	200	250	300	80	36	50	110	80	110	70	10	12	12	148
65	650	150	200	250	300	80	36	50	110	90	120	75	12	15	15	158

Andere Abmessungen auf Anfrage / Other dimensions on request / Otras dimensiones según consulta



FB Ketten

Die international patentierte FB-Profilkette ist das Resultat unserer kontinuierlichen Forschung und Entwicklung. Die FB-Profilkette wurde ursprünglich für den härtesten Einsatz in der Holz- und Papierindustrie entwickelt. Im Vergleich zu einer Standardkette weist die FB-Profilkette bei weniger Gewicht eine wesentlich höhere Bruchkraft und eine deutlich längere Lebensdauer auf.

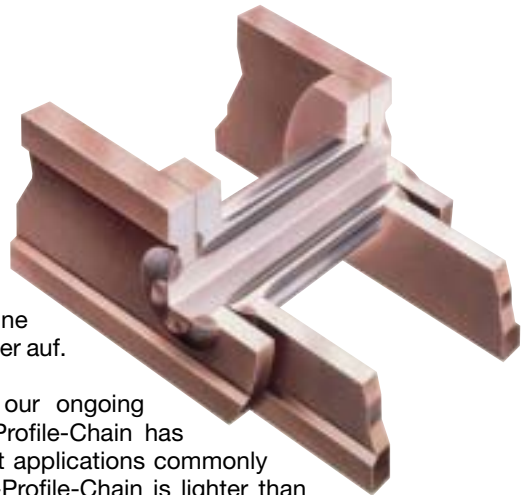

The international patented FB-Profile-Chain is the result of our ongoing research and development by FB Ketjutekniikka OY. The FB-Profile-Chain has been designed and developed for the most arduous and difficult applications commonly found in the timber log handling and paper industries. The FB-Profile-Chain is lighter than comparable standard chains and offers greater resistance to wear and shock loadings together with increased fatigue life.

La cadena perfilada FB, patentada internacionalmente, es el resultado de continuas investigaciones y desarrollos. Originariamente, el perfil FB fue desarrollado para su utilización bajo las condiciones de trabajo más duras de los sectores industriales del papel y de la madera. En comparación con las cadenas standad, el perfil FB permite con un peso menor una fuerza de rotura más alta y también una más larga duración.

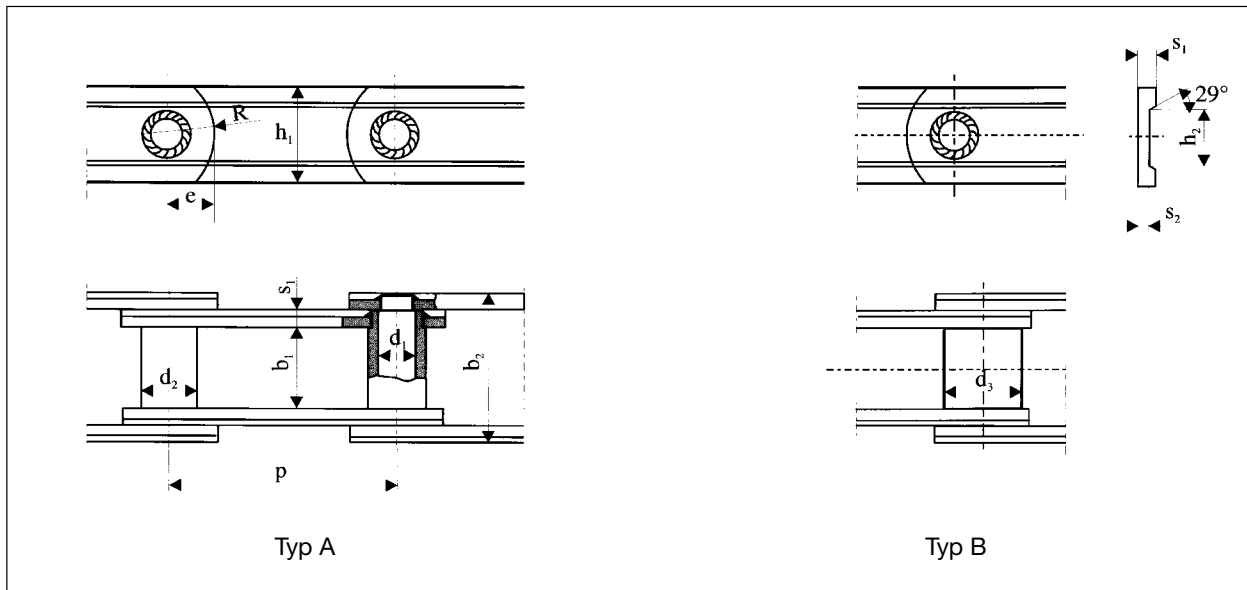

Die FB-Profilkette (patentiert) / The FB-Profile-Chain (patented) / Cadenas perfiladas (patentado)

Type	Bruchkraft/ Breaking Load (KN)	Teilung/ Pitch (p)	Lichte Weite/ Inner Width (b1)	Bolzen/ Pin (d1)	Buchse/ Bush (d2)	Schonrolle/ Small Roller/ (d3)	Lagerfläche/ Bearing Surface (cm ²)	Laschen							Gewicht/Weight (kg/m)	
								b2	s1	s2	h1	h2	e	R	Typ/Type A	Typ/Type B
P35 160	350	160	55	22	34	45	16,4	99	10	6,5	60	35	28	50	12,4	14,2
P35 200	350	200	55	22	34	45	16,4	99	10	6,5	60	35	28	50	11,3	12,7
P50 160	500	160	65	26	40	55	23	117	12	8	70	40	33	50	18,9	22,4
P50 200	500	200	65	26	40	55	23	117	12	8	70	40	33	50	17,3	20,1
P75 200	750	200	80	32	48	65	35	143	15	10	85	50	40	55	27,4	32,3
P75 250	750	250	80	32	48	65	35	143	15	10	85	50	40	55	24,8	28,8

Andere Abmessungen auf Anfrage / Other dimensions on request / Otras dimensiones según consulta



FB Ketten

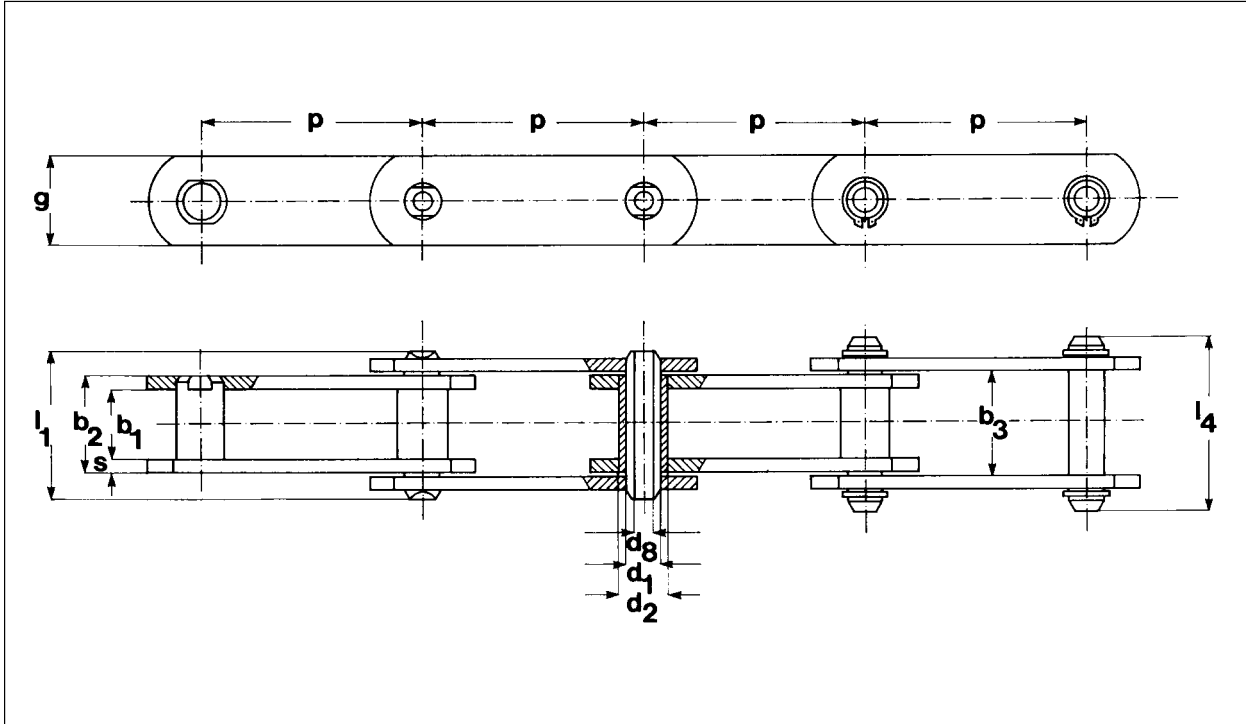

Hohlbolzen-Förderketten nach DIN8168 - ISO1977
Hollowpin-Conveyor-Chains DIN8168 - ISO1977
Cadenas de bulones huecos según DIN8168 - ISO1977

Type	Bruchkraft/ Breaking Load (KN)	Zulässige Belastung/ Allowed Load (N)	Teilung/ Pitch (p)	Lichte Weite/ Inner Width (b1)	Bolzen/ Pin (d8/d1)	Buchse/ Bush (d2)	Schonrolle/ Small Roller (d3)	Lauf- rolle/ Roller (d4)	Bundlauf- rolle/ Flanged Roller (d4/d5)	l1	Laschen/Plates			
											s	g	h1	h2
MC28	28	4000	63	20	8,2/13	17,5	25	36	36/45	40	3,5	25	35	22,5
			80											
			100											
			125											
			160											
MC56	56	8000	80	24	10,2/15,5	21	30	50	50/60	46,6	4	35	50	32,5
			100											
			125											
			160											
			200											
MC112	112	16000	100	32	14,3/22	29	42	70	70/85	63,8	6	50	70	45
			125											
			160											
			200											
			250											
MC224	224	32000	125	43	20,3/31	41	60	100	100/120	82,9	8	70	100	65
			160											
			200											
			250											
			315											

Andere Abmessungen auf Anfrage / Other dimensions on request / Otras dimensiones según consulta



FB Ketten

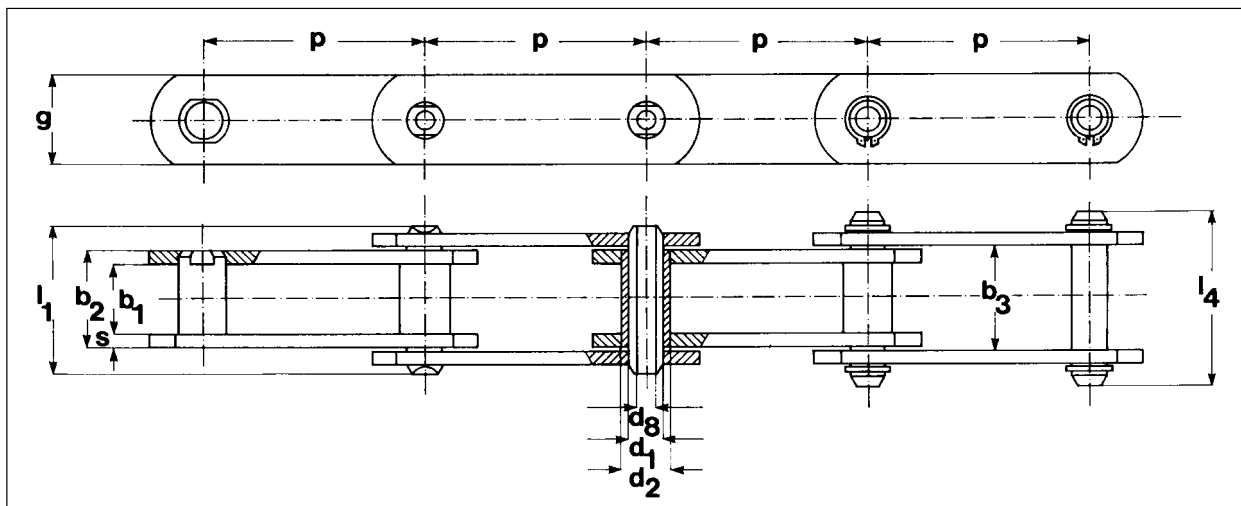

Hohlbolzen-Förderketten nach DIN 8165
Hollowpin-Conveyor-Chains DIN 8165
Cadenas de bulones huecos según DIN8165

Type	Bruchkraft/ Breaking Load (KN)	Zulässige Belastung/ Allowed Load (N)	Teilung/ Pitch (p)	Lichte Weite/ Inner Width (b1)	Bolzen/ Pin (d8/d1)	Buchse/ Bush (d2)	Schonrolle/ Small Roller (d4)	Lauf- rolle/ Roller (d5)	Bundlauf- rolle/ Flanged Roller (d5/d6)	l1	l2	Laschen/Plates	
												s	g
FVC63	46 *75	10500	63	22	8,2/12	18	26	40	50/60	46	55	4	30
			80										
			100										
			125										
			160										
FVC90	73 *90	15000	63	25	10,2/14	20	30	48	63/78	53	62	5	35
			80										
			100										
			125										
			160										
			200										
FVC112	90 *132	18700	100	30	11,2/16	22	32	55	72/87	63	72	6	40
			125										
			160										
			200										
			250										
FVC140	110 *170	23400	100	35	12,2/18	26	36	60	80/95	68	80	6	45
			125										
			160										
			200										
			250										
FVC180	145 *190	30000	125	45	14,2/20	30	42	70	100/120	68	100	8	50
			160										
			200										
			250										
			315										
FVC250	215 *300	41700	160	55	18,2/26	36	50	80	125/145	98	114	8	60
			200										
			250										
			315										

Andere Abmessungen auf Anfrage / Other dimensions on request / Otras dimensiones según consulta
***Laschen vergütet / *Sideplates tempered / *Mallas bonificadas**



FB Ketten

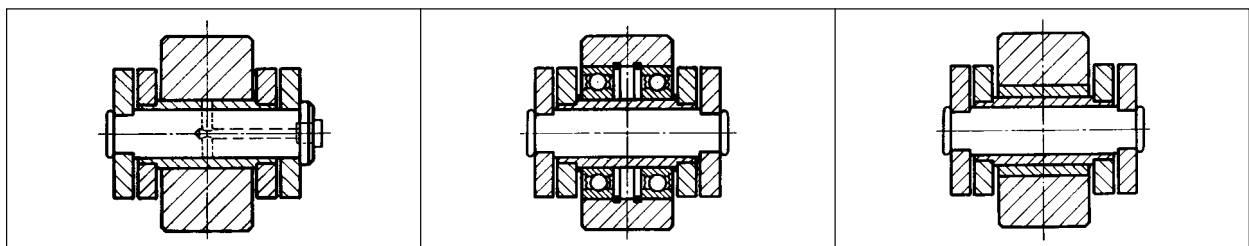
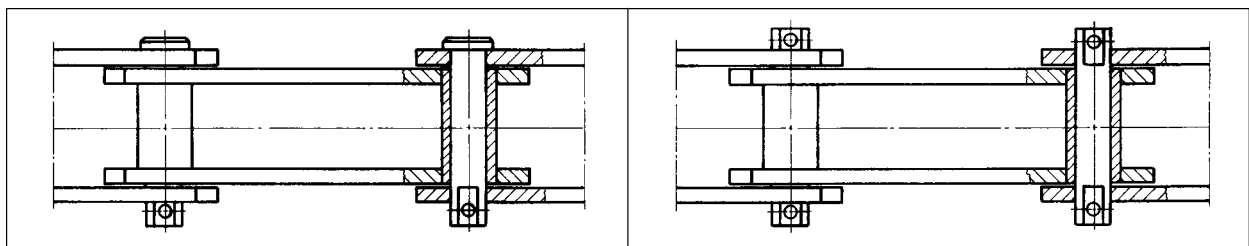
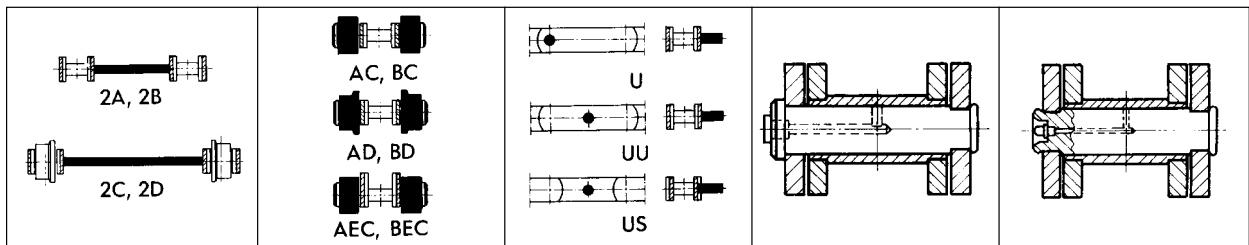
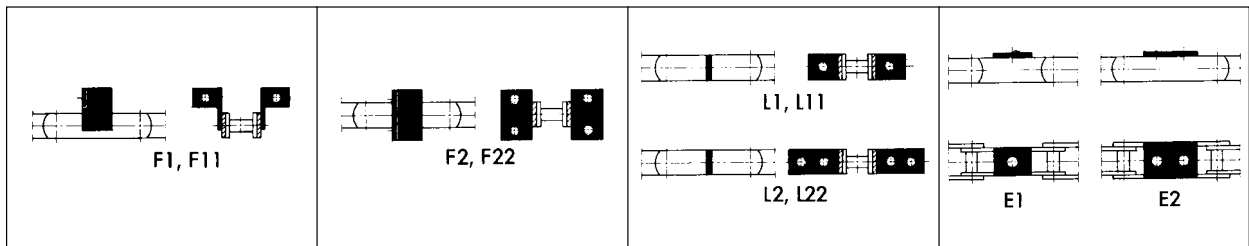
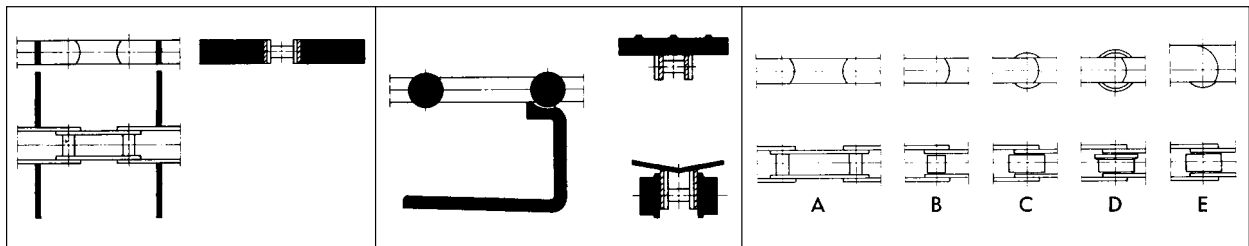
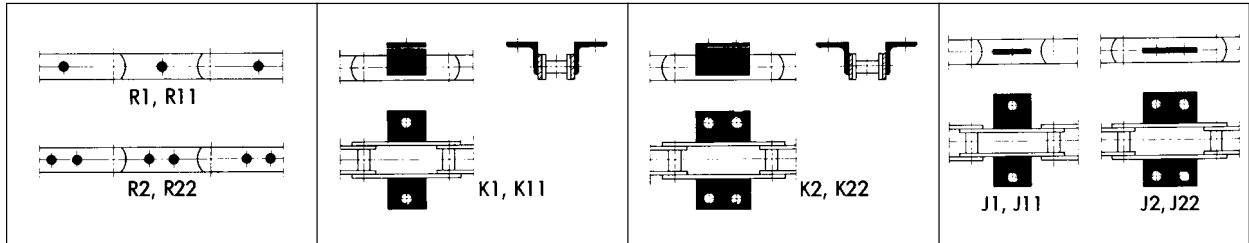



FB Ketten

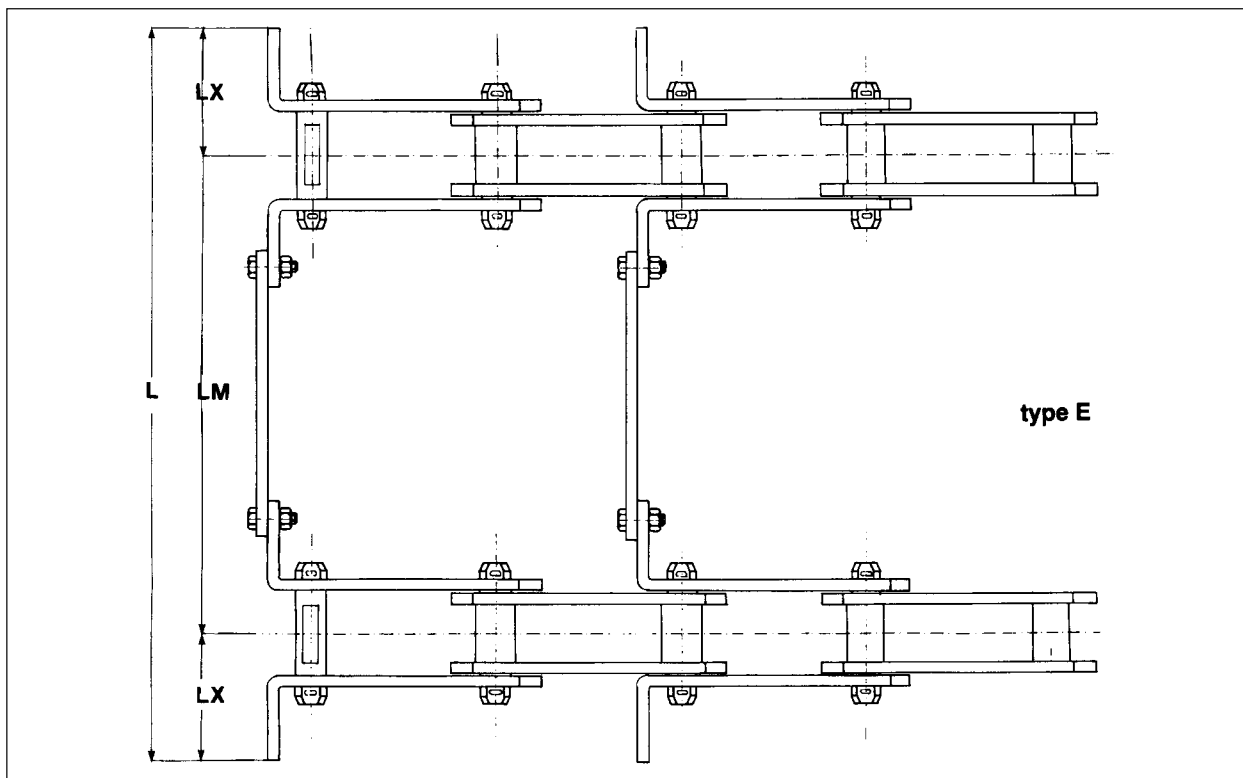
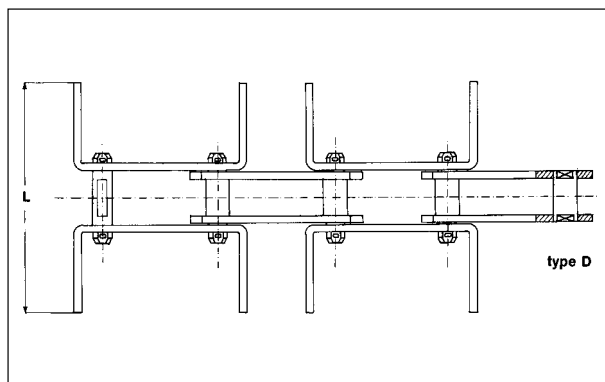
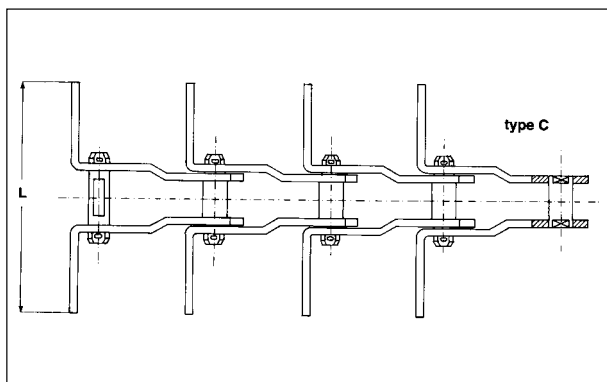
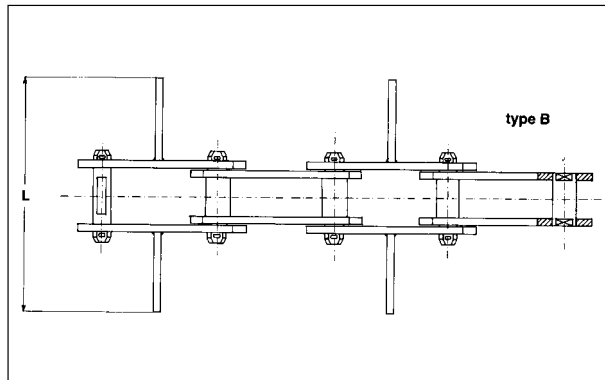
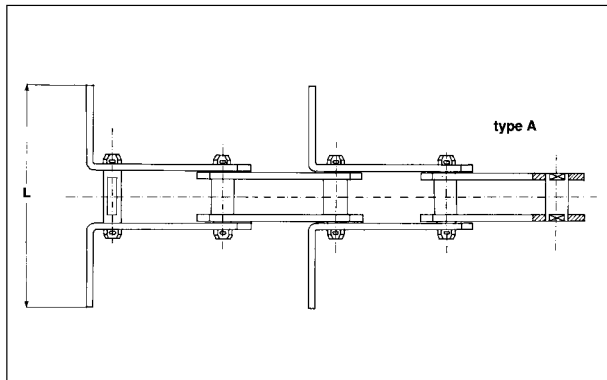



FB Ketten

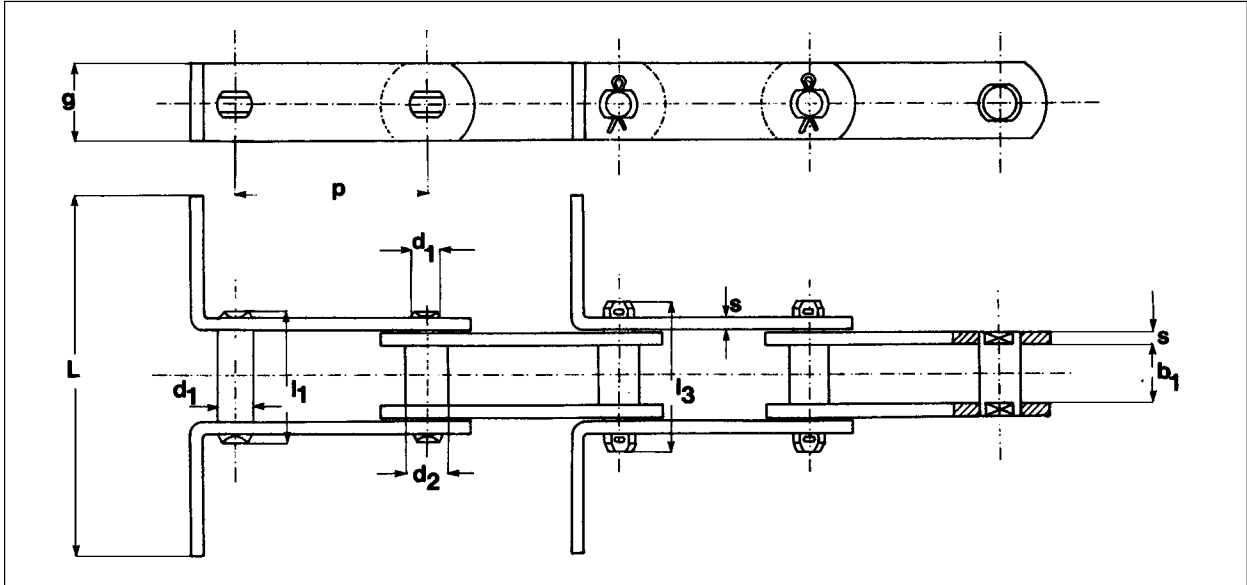

Kratzförderketten nach DIN 8167 / M-Serie
Scraper Chains according to DIN 8167 / M-Series
Cadenas tipo scraper, según DIN 8167 / Serie M

Type	Bruchkraft/ Breaking Load (KN)	Teilung/ Pitch (p)	Lichte Weite/ Inner Width (b1)	Bolzen/ Pin (d1)	Buchse/ Bush (d2)	Laschen/Plates			
						l1 mm max.	l2 mm max.	s	g
M56	A 56 / B 112	63	24	10	15	52	72	4	30
		80							
		100							
		125							
		160							
M80	A 80 / B 160	80	28	12	18	62	86	5	35
		100							
		125							
		160							
		200							
M112	A 112 / B 224	80	32	15	21	73	101	6	40
		100							
		125							
		160							
		200							
M160	A 160 / B 320	100	37	18	25	85	117	7	50
		125							
		160							
		200							
		250							
M224	A 224 / B 448	125	43	21	30	98	134	8	60
		160							
		200							
		250							
M315	A 315 / B 630	160	48	25	36	112	154	10	70
		200							
		250							
		315							

A = Einfachkette, B = Duplexkette / A = Simplex Chain, B = Duplex Chain / A = Cadena simple, B = Cadena doble
Andere Abmessungen auf Anfrage / Other dimensions on request / Otras dimensiones según consulta



FB Ketten

Kratzförderketten nach DIN 8165 / FV-Serie
Scraper Chains according to DIN 8165 / FV-Series
Cadenas tipo scraper, según DIN 8165 / Serie FV

Type	Bruchkraft/ Breaking Load (KN)	Teilung/ Pitch (p)	Lichte Weite/ Inner Width (b1)	Bolzen/ Pin (d1)	Buchse/ Bush (d2)	Laschen/Plates			
						l1 mm max.	l2 mm max.	s	g
FV40	A 40 / B 80	63 80 100 125 150 160	18	10	15	37	44	4	25
FV63	A 63 / B 126	63 80 100 125 150 160	22	12	18	46	55	4	30
FV90	A 90 / B 180	80 100 125 150 160 175	25	14	20	53	62	5	35
FV112	A 112 / B 224	100 125 150 160 175 200	30	16	22	63	72	6	40
FV140	A 140 / B 280	100 125 150 160 175 200	35	18	26	68	80	6	45
FV180	A 180 / B 320	125 150 160 175 200 250	45	20	30	86	100	8	50
FV250	A 250 / B 500	125 150 160 175 200 250	55	26	36	98	114	8	60
FV315	A 315 / B 630	150 160 175 200 250	65	30	42	117	133	10	70

A = Einfachkette, B = Duplexkette / A = Simplex Chain, B = Duplex Chain / A = Cadena simple, B = Cadena doble
Andere Abmessungen auf Anfrage / Other dimensions on request / Otras dimensiones según consulta